



Herefordshire Council Economy, Communities & Corporate Directorate

Highways Specification for New Developments

Specification



July 2006
Amended May 2015



Herefordshire Council
Economy, Communities &
Corporate Directorate

Highways Specification for New Developments July 2006 Amended May 2015



CONTENTS

General		4
	Notes for Guidance	4
G1	Definitions	5
G2	Scope of the Specification	6
G3	Substitution and Additional Clauses	6
G4	Breaking Open Existing Highway	6
G5	Typical Test and Supervision Procedure	6
G6	Works Adjacent to Existing Highway Structures	6
G7	Subcontracting of the Works	6
G8	Approval of Drawings Prior to Commencement	6
G9	Commencement of the Works	6
G10	Works to be to the Director of the Environment's Satisfaction	6
G11	Variation of the Works	7
G12	Access to the Works	7
G13	Signing, Lighting and Guarding	7
G14	Mud etc on Highway	7
G15	Pollution and Obstruction of Watercourses and Sewers	7
G16	Removal of Improper Materials and Workmanship	7
G17	Making Good Damage to Existing Highway	7
G18	Land Drains	8
G19	Archaeological Interests	8
G20	Health and Safety File	8
G21	CCTV Surveys	8
G22	Design Considerations	8
G23	Design of Construction Thickness	8
G24	Safety Requirements	9
G25	Notification of Emergency Telephone Numbers	9
G26	Preliminary Site Works	9
G27	Developers Obligations	9
G28	General Construction Requirements	9
G29	Surface Regularity and Tolerances	10
G30	Construction and Earthworks Materials	

Construction Specification	12
S1 Excavation and Filling	12
S2 Backfilling Trenches	12
S3 Weather Conditions	12
S4 Preparation of Formation	13
S5 Drainage of Sub Grade	13
S6 Carriageway Foundation	14
S7 Concrete and Grout	14
S8 Carriageway Bituminous Layers	15
S9 Kerbs and Channels	16
S10 Gully Grates and Frames	16
S11 Gully Pots	16
S12 Highway Drainage	17
S13 Manhole Covers and Frames	17
S14 Headwalls	18
S15 Footways/Cycleways	18
S16 Vehicular, Pedestrian and Cycle Crossings	18
S17 Verges and Visibility Splays	19
S18 Street Lighting	20
S19 Street Nameplates	22
Appendix A1 Construction thickness	24
Appendix B1 Testing to be Carried Out by the Contractor	25
Appendix B2 Testing Program and Requirements	24
Appendix B3 Electrical Testing	25
Appendix C1 Materials Compaction	25
Appendix C2 Compaction Plant	28
Appendix C3 Earthworks Compaction Table	29
Appendix C4 Sub Base Compaction Table	30
Appendix C5 Trench Reinstatement Compaction Table	31
Appendix D Bituminous Materials, Temperature Guidelines	32
Appendix E Standard drawing details	33
Drawings 001-019	34-52

Notes for Guidance

Under the CDM Regulations the Developer is regarded as the Client, anyone who has any input to the design process is regarded as a Designer and the Client must appoint a Planning Supervisor to oversee the key procedural stages. All of these roles within CDM have clear and specific responsibilities and obligations.

Personnel working in the Highway should possess NRSWA accreditation for their function.

The Developer shall comply with the Control of Pollution Act, Land Drainage Act and Environmental Protection Act in preventing the pollution or blocking of water supplies, watercourses. Contaminated land shall be suitably remediated and hazardous waste disposed of in compliance with current legislation and recorded within the CDM Health and Safety file.

On-site wheel washing equipment is normally stipulated as part of the Planning Consent and the Highway Agreement.

Any signing, temporary or permanent shall be illuminated so as not to dazzle, cause distraction or glare.

Prevention of Noise shall be in accordance with current best practice and the provisions of the Control of Pollution Act 1974 and any working times specified in the Planning Consent.

Dust, smoke and the arising from any cutting, sawing, grinding and drilling operations shall be contained or suppressed to ensure that no dust or debris escapes as air-born pollution.

GI Definitions

The Authority shall mean:	Herefordshire Council
The Developer shall mean:	The Person, Persons or Firm or Company as defined in the Agreement
The Agreement shall mean:	The Agreement under Section 38 or Section 278 of the Highways Act, 1980 agreed and entered into between the Authority and the Developer
The Specification shall mean:	Herefordshire Council's Highways Specification for New Developments
Director of Economy, Communities & Corporate shall Mean:	Mr G Hughes, Director of Economy, Communities & Corporate, Plough Lane, Hereford HR1 0LE or his appointed representative
The Works shall mean:	The Permanent Construction Works to be executed in accordance with this Specification as detailed on the Drawings and as defined in the Agreement
The Drawing shall mean:	The Plans Section and Details (and any subsequent amendment thereto) approved by the Director of Economy, Communities & Corporate and referred to in and attached to the Agreement
The Site shall mean:	The Lands owned by the Developer and the Minimum extent of such Public Highways and Public and Private Lands which in the opinion of the Director of Economy, Communities & Corporate is necessary and practicable for the proper construction of the Works
Approved Directed and Instructed shall mean:	Approved, Directed and Instructed by the Director of Economy, Communities & Corporate
B.S. shall mean:	The relevant British Standard current at the time of the execution of the Works
Sewer shall mean:	Sewers, Culverts and Drains of all descriptions (except sub-soil drains) whether for the conveyance of foul sewerage, storm water or surface water
Department for Transport Specification shall mean:	Latest Edition of the Department for Transport Specification for Highways Works hereafter called DfT SHW
Technical Approval for Highway Structure shall mean:	The procedures for technical approval of all highway structures as required by the Director of Economy, Communities & Corporate
The Testing Consultant:	A laboratory accredited by UKAS for the required tests or otherwise approved by the Director of Economy, Communities & Corporate
California Bearing Ratio (CBR):	A value derived from a standard test indicating the ratio of the strength of a particular soil compared with the corresponding strength of crushed rock
Subgrade:	Existing natural ground at and below formation.
Formation:	The level from which construction commences.
Carriageway:	The surfaced area of the road designed primarily for the passage of vehicles.
Highway:	A route where traffic has the right to pass. It may be restricted to particular classes of vehicles. The highway consists of the carriageway, cycleway and footway surfaces and includes any verges or vision splays.
Manhole:	A chamber constructed at specified intervals along drainage lines to allow access for cleaning or maintenance.
Gully:	An open topped pot usually made of concrete constructed at the carriageway edge to drain water from the carriageway. The aperture at the top of the gully is covered with a cast iron grating.
Channel:	A narrow strip usually placed at the edge of the carriageway designed to transfer surface water.
Cycleway:	The part of the carriageway over which cyclists have right of way.
Footpath:	A highway over which the public has right of way on foot only. It is remote from the carriageway.
Footway:	The part of the highway adjacent to the carriageway and is a right of way on foot only.

G2 Scope of the Specification

2.1 This specification refers and applies to the design and construction of highways and highway drainage constructed by or on behalf of a private Developer where the Council as the Highway Authority will, twelve months after the satisfactory proper and authorised completion of the works, undertake to adopt the highways and highway drainage as highways and highway drainage maintainable by the Authority at public expense.

G3 Substitute and Additional Clauses

3.1 Where any Works proposed to be undertaken by a Developer are deemed by the Director of Economy, Communities & Corporate not to be covered by the various Clauses of this Specification then the Director of Economy, Communities & Corporate shall, where he considers it desirable or necessary, issue, substitute or include additional Clauses and all details, drawings, substitutions and additional Clauses so issued shall be read and construed as forming part of this Specification.

G4 Breaking Open Existing Highway

4.1 Where it is necessary to break open an existing highway to lay or maintain apparatus, the Developer is required, under Section 50 the New Roads And Street Works Act 1991, to give prior notice to the Director of Economy, Communities & Corporate. 6 weeks notice must be given. The necessary application forms are available from the NRSWA Co-ordinator at Herefordshire Council.
<http://www.Hereford.streetworks@bblivingplaces.com>

No work shall be carried out until such notice has been given and approved

G5 Typical Test and Supervision Procedure - (Refer to Appendix B1, B2 & B3)

G6 Works Adjacent to Existing Highway Structures

6.1 No Works shall be carried out adjacent or at the approaches to, below, or through, on, or over any existing highway structure without the written permission of the Director of Economy, Communities & Corporate. Such permission will be withheld where the Director of Economy, Communities & Corporate considers the Works or the manner in which the Works are proposed to be carried out may endanger the structural condition, stability or safety of the structure.

G7 Subcontracting of the Works

7.1 Should the Developer appoint or intend to appoint any other person, persons, Firm or Company to construct the

Works (or any part thereof) on his behalf then he shall, not less than seven days prior to the commencement of the Works submit to the Director of Economy, Communities & Corporate in writing the name, office, address and 24 hour telephone number of the person, persons, Firm or Company to whom or to which the Works (or any part thereof) will be assigned.

7.2 Sub-contracting of the construction of the Works (or any part thereof) shall not in any way relieve the Developer from his obligations and liabilities under the terms of the Agreement and he shall be responsible for the acts, defaults and neglects of the person, persons, Firms or Company to whom or to which the Works (or any part thereof) have been assigned including their agents, servants or workmen as fully as if they were the acts, defaults and neglects of the Developer, his agents or workmen.

G8 Approval of Drawings Prior to Commencement of the Works

8.1 The Developer shall not commence construction of the works until he is advised in writing by the Director of Economy, Communities & Corporate that the Drawings and Documents including all details contained therein are sufficient and satisfactory in all respects, and that the arrangements and negotiations in respect of the Agreement are satisfactory or have been completed and concluded and the Agreements entered into.

G9 Commencement of the Works

9.1 The Developer shall not less than seven days prior to the commencement of the Works and after serving all required notices and gaining necessary permission, advise the Director of Economy, Communities & Corporate in writing of his intention to commence the Works. Work shall not proceed without the Construction Phase Health and Safety file being in place with the necessary Authorities.

9.2 The Developer shall not discontinue the Works without prior approval of the Director of Economy, Communities & Corporate and shall where such approval is given, notify the Director in writing of his intentions for securing, safeguarding and protecting the partially completed Works and indicating the anticipated period of cessation. The Developer shall give not less than five days notice in writing to the Director of Economy, Communities & Corporate of his intention to recommence the Works.

G10 Works to be to the Director of Economy, Communities & Corporate's Satisfaction

10.1 The Developer shall execute, complete and maintain the Works in strict accordance with the requirements of this Specification to the satisfaction of the Director of Economy, Communities & Corporate and shall comply fully with and

adhere strictly to the directions and instructions of the Director of Economy, Communities & Corporate.

10.2 The decisions of the Director of Economy, Communities & Corporate in respect of the requirements, provisions and interpretations of these General Conditions and Specification shall be final and binding.

G11 Variation of the Works

11.1 No variation of the position, alignment, dimensions, levels or construction details of the Works shall be made without the written consent of the Director of Economy, Communities & Corporate.

G12 Access to the Works

12.1 The Director of Economy, Communities & Corporate and any other persons authorised by the Director of Economy, Communities & Corporate shall at all times have access to the Works.

G13 Signing, Guarding and Lighting

13.1 The Developer shall provide and maintain any necessary watching and lighting, temporary barricades, traffic control, etc., as required for the safe execution of the Works. For emergency use outside normal working hours, the Developer shall prior to the commencement of the Works, provide the Director of Economy, Communities & Corporate in writing with the name, daytime and night-time telephone numbers and address of the person responsible for site security and traffic safety and control. The Developers must obtain the approval of the Director of Economy, Communities & Corporate before using any temporary signals on the existing highway.

G14 Mud etc on Highway

14.1 The Developer is reminded that it is an offence under the Highways Act 1980 to deposit or allow materials to be washed onto a Highway and should therefore take all reasonable steps to ensure that the Highway is kept clear of all mud, clay, lime or similar material during the execution of the project. It may be necessary to provide wheel washing facilities to ensure that all vehicles leaving the site are sufficiently clean to ensure that no materials are deposited on the Highway.

14.2 The existing public highway must not be used for stockpiling or storing plant, materials or equipment. The use of the existing publicly maintained Highway by plant and machinery is likely to cause damage to the Highway and the Developer/Contractor will be liable for the cost of the reinstatement under Section 59 of the Highways Act 1980 if any damage has been caused to the Highway.

G15 Pollution and Obstruction of Watercourses and Sewers

15.1 The Developer shall not during the construction and maintenance of the Works allow any naturally occurring materials, construction, and building materials, chemical, poisonous and inflammable substances, obnoxious solid, gasses or fluids, sewage or other organic and inorganic impurities to be discharged from the Works and cause pollution or obstruction to any canal, river, watercourse, ditch or surface water sewers and drains.

15.2 Should the Developer be aware that pollution is being caused by reason of his operations then he shall immediately cease the operation causing or considered to be causing the pollution and shall as a matter of urgency and without delay inform the relevant Environment Agency and the Director of Economy, Communities & Corporate of the location and estimated extent of the pollution and the action being taken to alleviate or prevent further pollution taking place. The Developer shall recommence the operations only when he has taken effective preventative measures to the satisfaction of the Environmental Agency and the Director of Economy, Communities & Corporate to ensure that no further pollution will occur.

G16 Removal of Improper Materials and Workmanship

16.1 The Director of Economy, Communities & Corporate may during the progress of the construction of the Works order the following should he deem necessary:

- i) The removal from the site of any materials not complying with the requirements of this Specification.
- ii) The substitution with materials complying with the requirements of this Specification.
- iii) The removal and proper re-execution of any work which in the opinion of the Director of Economy, Communities & Corporate has not been constructed in accordance with the Drawings and/or to the requirements of this Specification.

G17 Making Good Damage to Existing Highway

17.1 Prior to commencement of the works, the Developer shall arrange for the existing highway network, to be used by construction traffic, in the vicinity of the site to be inspected in the presence of the Director of Environments representative and a video record of its condition made for future reference.

17.2 Where the surface of any existing highway or public area of any kind has been disturbed during the course of the Works,

these shall be fully reinstated with similar materials to the satisfaction of the Director of Economy, Communities & Corporate.

17.3 Any damage sustained to the footways, verges, carriageways or existing public highway by delivery vehicles and plant servicing the development shall be deemed to be the responsibility of the Developer. Such damage shall be rectified to the Authority's satisfaction before adoption of the development roads will be considered and shall be remedied at the Developer's expense.

17.4 Failure on the Developer's part to so do may result in the Council or its Agent carrying out these works and recharging all costs incurred to the Developer.

G18 Land Drains

18.1 The Developer shall replace any land drains which have been disturbed in carrying out the Works and make good the same in a manner and with materials similar to those previously existing or otherwise shall deal with such land drains as the Director of Economy, Communities & Corporate may direct.

G19 Archaeological Interests

19.1 These will usually have been considered and negotiated through the planning process in relation to building proposals. However, from time to time archaeological discoveries may be made in the course of estate road construction. These must be notified to the Herefordshire Archaeologist, HARC, Fir Tree Lane, Rotherwas, Hereford HR2 6LA. Telephone Number 01432 383350.

The Archaeological Adviser will arrange for an inspection and rapid recording or removal of material. Notification will not result in undue delays in construction.

G20 Health and Safety File

20.1 In accordance with the requirements of the Construction (Design and Management) Regulations 2015 (CDM), Developers are required to submit a Health and Safety File to the Council.

20.2 The information contained in the file needs to include that which will assist persons carrying out work on the highway infrastructure at any time after the completion of the project in question and needs to include:-

- Brief description of the works carried out
- Record or 'as built' drawings
- Design calculations and assumptions
- General details of construction methods and materials used

- Details of any equipment and maintenance facilities
- Details of any highway structures including maintenance procedures and requirements
- Details of the location and nature of all utilities and services including emergency and fire fighting systems
- Residual hazards and how they have been dealt with
- Any hazards associated with the materials used

20.3 The file must be submitted as soon as the project has reached practical completion. Failure to submit this information in a timely manner will prevent the issuing of a provisional certificate of completion.

G21 CCTV Surveys

21.1 Prior to final surfacing the Developer is required to carry out a CCTV survey, at his own expense, and provide a visual and written record of the result for any highway drains constructed. Prior to carrying out the survey, the Developer shall ensure that the sewers and manholes are clean and that all debris has been removed from connecting sewers and drains. Prior to final adoption, a further CCTV survey may be required at the discretion of the Director of Economy, Communities & Corporate.

G22 Design Considerations

22.1 This construction Specification should be read in conjunction with Herefordshire Council's Highways Design Guide for New Developments.

22.2 The design is to take all necessary precautions to ensure that water from privately owned land/properties does not drain directly into the Highway drainage system. It is a requirement of the Highways Act 1980 to ensure that this is the case.

22.3 Work will not be allowed to commence until the Director of Economy, Communities & Corporate has approved the Section 38/278 plans in writing.

G23 Design of Construction Thickness

23.1 Carriageway construction constituent material depths are shown in appendix A1.

23.2 The Developer is required to undertake a ground investigation prior to undertaking initial design in order to establish the soil classification, moisture contents, plasticity indexes and CBR values. Material taken for testing is to be sourced from trial pits or boreholes taken through the centre line of the proposed highway at intervals of no more than 40m. However, this frequency may be amended dependant on the prevailing site conditions.

23.3 Where the development is to be undertaken in areas that exhibit soft ground, buried structures, landfill sites etc special design measures may need to be considered by the developer. The detailed design so produced to cater for these eventualities must be approved by the Director of Economy, Communities & Corporate prior to any construction works taking place.

23.4 Sampling and testing shall be undertaken in accordance with the relevant current British Standards. All laboratory analyses are to be reported on UKAS certificates. It is possible that other reporting formats may be utilised, however, they must be approved by the Director of Economy, Communities & Corporate prior to use.

G24 Safety Requirements

24.1 The developer shall be responsible for all safety aspects of the works prior to completion.

24.2 The Developer shall be responsible for the Construction (Design and Management) Regulations 2015 in relation to the Development and all works associated with it. The Developer is to ensure that all handling and installation processes are undertaken in accordance with The Health and Safety at Work Act 1974 and Manual Handling Operations Regulations 1992.

24.3 Before the commencement of the works, the Developer shall notify the Director of Economy, Communities & Corporate of the identity of the Planning Supervisor in accordance with the Construction (Design and Management) Regulations 2015.

24.4 The Developers responsibility under the Health and Safety at Work Act is also extended to its sub contractors, operatives, council Officers and members of the public who may have access to the site. As the street manager the Developer is responsible for the Highway including all matters pertaining to health and safety until such time as Herefordshire Council formally adopts the Highway.

G25 Notification of Emergency Telephone Numbers

25.1 The Developer/Contractor will erect and maintain an information board on site for the duration of the works. The board will provide the name and contact phone number of a responsible person for the works. The person will be available 24 hours a day, 7 days a week to allow notification of dangerous event, incident or accident should they occur. The information board must be clearly visible from the adopted Highway.

G.26 Preliminary Site Works

26.1 The Developer is to ensure that the following Licences have been obtained prior to carrying out any works within the adopted Highway:

Scope of Works	Licence Required
Placing apparatus within the Highway	Street Works Licence

The Director of Economy, Communities & Corporate must be given at least one weeks notice prior to the commencement of the Highway Works. This period will be increased to 28 days where works are to be undertaken within Traffic Sensitive Routes.

26.2 All works are to be carried out to the satisfaction of the Director of Economy, Communities & Corporate.

26.3 The Developer may be required to prove the integrity of the works at any stage of the project that the Director of Economy, Communities & Corporate may stipulate. If there is a need to prove the thickness of a particular material layer that has been covered prior to inspection then the Developer will be required to undertake coring to indicate the as constructed thickness. This work will be undertaken at the Contractors expense.

26.4 All Roads and visibility splays shall be set out and laid in accordance with the approved plans and associated Specification. They are to be maintained in this form until the completion of all works.

26.5 At the location(s) where the new development Highway joins the existing Adopted Highway, the new junction bellmouth, visibility splays and footways are to be constructed to finished surfacing levels prior to any other works commencing on site. Resurfacing/construction of the existing footway(s)/carriageway(s) are to be extended to include any reinstatements or service trenches connected with the new Development. Reinstatement edges are to be cut back to a clean vertical edge and the development constructed up to that point. The surfacing course shall be overlapped by 300mm with the vertical joint receiving hot applied 50 pen bitumen. (Refer to drawing appendix standard detail)

26.6 No storage of materials will be allowed on the Adopted Highway and all visibility splays are to be maintained during the construction works.

G27 Developers Obligations

27.1 The Developer and his sub contractors shall take full responsibility for the stability and safety of all site operations and methods of construction from commencement through to final adoption.

27.2 The Developer/Contractor shall adhere to the provisions of all general or local Act of Parliament and the regulations and bylaws of any local or statutory authority during the construction of the development.

27.3 The Developer shall employ a competent and experienced supervisor on site at all times. The supervisor and all operatives shall be NRSWA accredited.

27.4 Sub contractors engaged on the development will also be covered under the above Clause.

G28 General Construction Requirements

28.1 All materials used in or upon the works are to be in accordance with the appropriate British Standard Specification and Volume I of the Highways Agency's Manual of Contract Documents for Highway Works. All materials shall be kitemarked or produced within an approved Quality Assurance Scheme.

All materials used within 450mm of finished surface level shall be non-frost susceptible as defined in Clause 602.19 of Highways Agency (HA) Specification for Highway Works.

28.2 Kerbs shall be installed prior to the construction of base layers.

28.3 Gully and Manhole covers within the Highway including footway ironwork shall not be set to their final level until the completion of the installation of all base course materials.

28.4 Any exposed bituminous layer must be protected and kept clean for as long as it remains exposed prior to the construction of the next layer. Where layers have become contaminated the area is to be cleaned to the satisfaction of the Director of Economy, Communities & Corporate and, before the next layer is placed the area is to receive a tack coat layed in accordance with the requirements of Clause 920.7 of Volume I Manual of Contract Documents for Highway Works. If the layer is damaged it shall be removed and replaced with material of suitable specification.

28.5 All road, footway and cycleway bituminous materials shall be machine layed unless the Director of Economy, Communities & Corporate has approved hand laying methods. The carriageway shall be laid in two passes with the joint being

at the centre line of the carriageway. The laying of bituminous materials will not be allowed until all service installation has been completed.

28.6 All blockwork shall be protected from site traffic during the execution of the works. Any damage is to be made good to the satisfaction of the Director of Economy, Communities & Corporate at the Developers expense.

28.7 All highway verges are to be a minimum of 0.5m wide and are to be laid as grassed areas in accordance with Section 17.

28.8 A sustainable approach to highway construction with particular emphasis on the use of recycled material is encouraged. Testing for material in recycled coarse aggregate and recycled concrete aggregate is to be undertaken in accordance with Clause 710 of Volume I Manual of Contract Documents for Highway Works. Herefordshire Council has a committed approach to the use of recycled materials and can provide an approval process including technical assessment and laboratory appraisals as necessary. It may be possible to use recycled materials within appropriate construction phases provided that they do not affect the structural or performance characteristics of the development. The approval process will be undertaken at the expense of the Developer.

28.9 It is recommended that the Developer and his sub contractors produce and maintain a waste register. The waste register will detail all surplus materials that are disposed of from site. This will allow an analysis to be performed indicating total wastage, hence lost revenue from the project. It will therefore be possible for the Developer to formulate and administer procedures in order to minimise the amount of wastage from site, which in turn will assist in maximising profitability as well as helping to safeguard the environment.

G29 Surface Regularity and Tolerances

29.1 The surface regularity of the completed surfaces of estate road carriageways shall comply with the following table:

Transverse and Longitudinal Straight Edge Measure BS594987:2015 / BS7533-4:2006

Max deviation under a 3m straight edge

Surface Course	7mm
Binder Course	13mm
Base Course	25mm
Sub-base	30mm
Blockwork	6mm and max 2mm difference in level between adjacent blocks

Additionally, for estate roads exceeding 40m in length and for associated cycleways, footways, footpaths and shared surfaces without drop kerbs a longitudinal rolling straight edge test in accordance with MCHW Vol I Series 700 will also apply.

29.2 Trenches cut through any carriageway must be reinstated such that the finished wearing course profile is level with the immediately adjacent surface.

29.3 The Developer shall set all fixed surface features, boxes and ironwork in footway, cycleway or carriageway to coincide with the level of the immediately adjacent surface. This work must be undertaken prior to the application of the wearing course.

29.4 The difference in level of a fixed surface feature and the adjacent surface shall not exceed a tolerance of +/-6mm except for those contained in the following Table:

Tolerances for Other Fixed Surface Features

Kerb Upstand	125mm +/-5mm
Vehicular Crossing Kerb Upstand	25mm +/-3mm
Pedestrian and Cycleway Crossing Kerb Upstand	3mm +/- 3mm
Surface adjacent to Gullies (BS 7533 Pt3)	+5mm to +10mm

29.5 Where kerbs are required to be flush with the carriageway the tolerance shall be +3mm.

29.6 For a diagrammatic detail of the stepped construction detail refer to Appendix E.

G.30 Construction and Earthworks Materials

30.1 General

All materials incorporated into the works shall comply with the relevant current British Standards and/or the current edition of the Department of the Environment and The Highway Agency Specification for Highway Works (hereafter referred to as SHW). This requirement also applies to installation and workmanship. The materials shall be approved by the Director

of Economy, Communities & Corporate and due access shall be allowed to the Director of Economy, Communities & Corporate for the purpose of sampling and testing.

30.2 Earthworks Material and Compaction

Definitions of Earthworks materials along with the requirements of compaction of earthworks, sub base and trench reinstatements are contained within Appendix C1, C2, C3, C4 and C5 (Refer to the Specification for Highway works for compaction requirements)

30.3 Compaction Plant

Details of suitable compaction plant are provided within section C3, C4 and C5 and compaction Tables for materials are provided as follows:
(Refer to the Specification for Highway Works)

Earthworks	Appendix C3
Sub-base	Appendix C4
Trench Reinstatement	Appendix C5

30.4 Concrete for Ancillary Purposes

All materials shall comply with the SHW Clause 1704 and BS8500.

S1 Excavation and Filling

- 1.1 Topsoil Strip
- 1.2 Excavation to Formation
- 1.3 Areas Below Formation
- 1.4 Forming Areas Of Fill
- 1.5 Granular Material Backfill

1.1 Topsoil Stripping

1.1.1 Turf, topsoil and other organic and unsuitable materials shall be stripped from all areas beneath proposed carriageways, cycleways, footways and embankments to a minimum depth of 150mm or as directed.

1.1.2 Topsoil shall be suitably stockpiled to a maximum depth of 2m and protected to prevent rainfall scour and loss due to wind. The stockpiles should be stored separately from other materials to avoid cross contamination.

1.1.3 No material shall be deposited within 5m of any trees or as directed should a tree preservation order be in place.

1.2 Excavation To Formation

1.2.1 The proposed area shall be excavated to a depth of 150mm or as directed. Unsuitable material is to be removed and be replaced with approved granular material as described within S1.5.1.

1.3 Areas Below Formation

1.3.1 Areas below formation following the removal of turf etc are to be made up with approved suitable fill as detailed within Appendix C1.

1.3.2 Approved granular fill shall be used to fill any ditches or similar that run beneath the line of the proposed works. The line of ditch should be piped if it is necessary to maintain flow along this drainage path. If this is the case, the Developer should liaise with Hereford Council or the Environment Agency.

1.3.3 Approved granular material should also be used to fill isolated deep pockets such as old basement voids. Any vertical walls shall be broken out to below formation level and the granular material placed and compacted within the void to the requirements of C1, C2, C3, C4 and C5.

1.4 Forming Areas of Fill

1.4.1 Material used to make up levels to formation shall be placed and compacted in accordance with the requirements of Appendix C1, C2, C3, C4 & C5

1.4.2 Material used to form embankments shall be to the requirements of appendix C1.

1.4.3 Any widening works to carriageways on embankments must be undertaken with approved granular material to the

requirements of Appendix C1. The material shall be benched in and compacted in accordance with Appendix C3.

1.5 Granular Material Backfill

1.5.1 Suitably approved granular material shall include the following characteristics:

Characteristic	Acceptance Criteria
10% Fines Value	>40Kn soaked basis (BS812)
Grading	Well graded <9% passing 63µm sieve
Max Particle Size	<63mm

Additionally, the material must be free of clay and other contaminants. Alternatively, Type 1 or Type 2 Granular sub base may be used.

1.5.2 If a granular material other than that specified within S1.5.1 has been placed as fill and exhibits a deficiency in fines including an open textured compacted surface then the following action should be taken:

- Spread a fine granular material over the surface and vibro rolled in to fill all prevalent voids prior to the placement of sub base.
- If this is not satisfactory a separating membrane shall be installed prior to the placement of the sub base.

S2 Backfilling Trenches

2.1 Backfill Materials and Construction Depths

2.1.1 Trench reinstatements on site should be undertaken in accordance with this Specification.

2.1.2 Trench reinstatements in the existing Highway are to be undertaken in accordance with the requirements of 'NRSWA Specification For The Reinstatement Of Openings In Highways'.

S3 Weather Conditions

3.1 Earthworks Operations

3.2 Construction

3.1 Earthworks Operations

3.1.1 Working in wet conditions will adversely affect and damage existing ground including the Sub base and sub grade. If these materials have deteriorated due to trafficking then the material shall be removed and replaced with Type 1 material or material corresponding to S1.5.1.

3.1.2 No material in a frozen condition may be incorporated into the works.

3.2 Construction

3.2.1 No material shall be laid on any surface that is frozen or covered with ice or snow.

3.2.2 Materials incorporating bitumen binders shall not be laid where the temperature of the surface to be covered is below 2°C. If the surface is dry and free of ice or snow then laying may proceed where the air temperature in the shade is at or above -1°C provided the temperature is rising.

3.2.3 Footway and cycleway surface courses cannot be laid in cold, windy or wet conditions unless precautions can be taken to ensure that the material is compacted above its minimum laying temperature.

3.2.4 The Developer is to consider the adverse affects of applying coated chippings to rolled asphalt materials in cold weather conditions. Wind chill factors can rapidly reduce the temperature of the laid material and the Developers attention is drawn to the minimum rolling temperatures contained within Appendix D.

3.2.5 Materials containing cement shall not be laid when the descending air temperature in the shade falls below 3°C and laying shall not be resumed until the air temperature reaches 3°C.

3.2.6 Where fresh concrete or mortar containing Portland Cement has been placed within the works and the temperature is expected to fall below 0°C within a period of up to 48 hours after placing, then suitable insulating blankets should be used to ensure that the materials do not freeze. These blankets must remain in place until the air temperature is at 3°C and rising. The Developer must be made aware that the incorporation of additives or cement replacements may retard the early strength gain. Care should therefore be taken to ensure that damage does not occur after the initial 48-hour period.

S4 Preparation of Formation

4.1 Shaping and Compaction

4.2 Weather Protection

4.3 Geotextile Requirements

4.4 Shared Surface, Access Ways and Industrial Estate Roads

4.1 Shaping and Compaction

4.1.1 Following reinstatement of any defective areas the formation shall be cleaned of any mud and slurry prior to being compacted with a roller of suitable weight and type. The resulting profile shall be properly shaped to an even and uniform surface in accordance with the design levels.

4.1.2 At this stage the Developer shall obtain the approval of the Director of Economy, Communities & Corporate before further works can proceed.

4.1.3 Any depressions that occur during compaction shall be filled with an approved material and compacted to the required standards.

4.2 Weather Protection

4.2.1 The formation shall be adequately protected from the weather and shall not be used by construction traffic. The area should be covered with sub base as soon as is practicable.

4.3 Geotextile Requirement

4.3.1 If the CBR value of the formation is <5% or the formation is formed within a cohesive material a separating membrane with the properties indicated below will be laid on the prepared formation.

4.3.2 The separating membrane shall extend 300mm outside the kerb line and comply with the following:

- In accordance with SHW Specification
- The minimum tensile strength in each direction shall be 6kN/m

4.4 Shared Surface, Access Roads and Industrial Estate Roads

4.4.1 Shared Surface, Access Roads and Industrial Estate Roads must comply with the above requirements over their entire width.

S5 Drainage of Sub Grade

5.1 General

5.2 Alternative Provisions

5.1 General

5.1.1 Adequate drainage shall be provided on all sites to ensure that the water level is maintained at a depth of at least 300mm below formation. The sub Grade drain pipes must be run to an approved outfall.

5.1.2 Subgrade drainage may not be required where the formation is not rutted and there is no evidence of free standing water, and

- Where a site investigation has deemed that the highest annual ground water level is 300mm or greater below formation
- Free draining sand and gravel strata are prevalent at formation

5.2 Alternative Provision

5.2.1 Where Subgrade drainage has been found to be required but is impractical to achieve separating membranes shall be placed above and below an additional 150mm layer Of Type I sub base which is to be installed below and extra to the depth required by the Plasticity Index.

S6 Carriageway Foundation

- 6.1 General**
- 6.2 Sub Formation and Capping**
- 6.3 Capping Material**
- 6.4 Sub Base material**

6.1 General

6.1.1 Refer to appendix A1 for design depths for construction. Sub base material is to be spread evenly on the formation in layers not exceeding 150mm thick. The material is to be compacted in accordance with the requirements of Appendix C1, C2, C3, C4 and C5. The moisture content of the material is to be within the range optimum -2% or +1% and must not be segregated.

6.1.2 The full thickness of the sub base should be continued to 300mm beyond the back of kerb.

6.2 Sub Formation and Capping

6.2.1 Capping layers shall be provided to the thickness shown within Appendix A1 unless otherwise directed by the Director of Economy, Communities & Corporate. Where insitu tests show CBR values less than those predicted at design stage either the whole area of capping shall be increased in thickness or localised soft areas shall be excavated and replaced with a new layer of capping material.

6.2.2 The sub formation shall have the same longitudinal gradient, cross fall and surface level tolerance as the formation.

6.2.3 Any damage to sub formation or capping by the use of construction traffic, or otherwise shall be made good to the satisfaction of the Director of Economy, Communities & Corporate.

6.3 Capping Material

6.3.1 Capping material shall comply with the requirements set out in DfT SHW, Clause 613, Class 6F1 or 6F2. The minimum Ten Per Cent fines Value for 6F2 shall be 50kN.

6.4 Sub Base Material

6.4.1 Type I sub base conforming to SHW Clause 803 to be used. The material is to fully comply with the requirement of SHW clause 803 granular material Type I sub base.

S7 Concrete and Grout

- 7.1 Concrete**
- 7.2 Concrete Aggregates**
- 7.3 Storage of Concrete Aggregates**
- 7.4 Cement**
- 7.5 Rapid Hardening Cement**
- 7.6 Sand**
- 7.7 Water**
- 7.8 Grout**

7.1 Concrete

7.1.1 Concrete shall be either site batched or ready mixed, and shall comply with the requirements of The DfT SHW, Clause 1704 and BS8500.

7.2 Concrete Aggregates

7.2.1 Aggregates shall comply with DfT SHW, Clause 1702.

7.3 Storage of Concrete Aggregates

7.3.1 Fine and coarse aggregates shall be separately stored on a free draining hard standing or similar clean foundation, kept clean and free from all impurities and foreign substances, and protected from frost.

7.4 Cement

7.4.1 Cement shall comply with BS EN 197 Portland cements or BS4027 Sulphate resisting Portland cement.

7.4.2 Ordinary Portland cement shall be used unless otherwise directed by the Director of Economy, Communities & Corporate.

7.5 Rapid Hardening Cement

7.5.1 Approved rapid hardening cement may be used in lieu of Ordinary Portland cement only with the prior approval of the Director of Economy, Communities & Corporate. All special conditions stipulated by the manufacturer of the brand concerned as to its use shall be strictly observed.

7.6 Sand

7.6.1 Sand shall be clean washed, sharp, pit or river sand free from clay, organic matter etc and comply with BS EN 12620.

7.7 Water

7.7.1 The Contractor shall be responsible for making his own arrangements with the Water Company for obtaining mains water and he shall comply with all local conditions regarding its use.

7.7.2 If water for the works is not available from a Public Utility Undertaking Supply, the approval of the Director of Economy, Communities & Corporate shall be obtained regarding the source of supply and manner of its use. If so required, the Contractor shall arrange for tests of the water to be carried out in accordance with BS EN 1008 and it shall only be used if the test results are satisfactory.

7.8 Grout

7.8.1 Cement grout for general use shall be used within one hour of mixing and shall consist of Ordinary Portland or Sulphate Resisting Portland Cement and water mixed in the proportions necessary to ensure that the mix has adequate workability and a suitable consistency for the intended use. Unless as the result of grouting trials or where otherwise directed by the Director of Economy, Communities & Corporate, the maximum water cement ratio for any grout for general use shall be 0.5.

S8 Carriageway Layers

8.1 General

8.2 Bituminous Materials

8.3 Base Layer- Dense Bitumen Macadam

8.4 Binder Layer-Dense Bitumen Macadam

8.5 Carriageway Surface Course

8.6 Concrete Block Paving

8.1 General

8.1.1 Refer to appendix A1 for general material Specification requirements and layer thicknesses.

8.1.2 Bituminous materials shall be machine laid with the exception of small areas with prior approval of the Director of Economy, Communities & Corporate

8.1.3 Where damage occurs to the previously laid bituminous materials then the area shall be rectified to the satisfaction of the Director of Economy, Communities & Corporate prior to being overlain.

8.1.4 Guidelines for delivery and rolling temperatures are given in Appendix D.

8.1.5 All vertical faces of ironwork within the wearing course depth are to be coated with cold applied or hot bitumen immediately prior to the laying of the wearing course.

8.2 Bituminous Materials

8.2.1 The base layer(s) material shall be Dense Bitumen Macadam to S8.3.1 below. The materials formulation and compaction standards shall be such to ensure that insitu air voids are more than 2% but less than 10%. For compliance, all DBM materials shall conform to the requirements of the Specification for Highway Works Clause 929.

8.3 Dense Bitumen Macadam-Base Layer

8.3.1 The material shall be AC32 dense base 100/150 rec conforming to DfT SHW 906. It shall be placed in 2 layers of equal thickness and thoroughly compacted.

8.4 Dense Bitumen Macadam-Binder Layer

8.4.1 The material shall be AC20 dense bin 100/150 rec conforming to DfT SHW 906. It shall be compacted to the same standards as the base layer.

8.5 High Stone Content/Hot Rolled Asphalt – Surface Course

8.5.1 The material shall be High Stone Content/Hot Rolled Asphalt – HSC/HRA 55/10 F Surf 40/60 des minimum PSV 55, conforming to DfT SHW 911.

8.6 Concrete Block Paving

8.6.1 Block paving in the form of precast concrete rectangular blocks of dimensions 200 x 100 x 80mm laid on a laying course in accordance with S8.6.3 below.

8.6.2 Blocks shall comply with BS1338:2003 and the permitted colours are to be determined by the Director of Economy, Communities & Corporate.

8.6.3 Blocks shall be laid on a 30mm compacted thickness of category II laying course (sharp) sand in accordance with the requirements of BS 7533. The method detailed in 4.3.3.a, of that document shall be adopted for installing the laying course.

8.6.4 Surface regularity for Blockwork is defined in G29.1.

8.6.5 Gaps between kerb face and blocks and between ironwork and blocks must be kept to a minimum and sealed with a well rammed mixture of 3:1 dry clean sharp sand to O.P.C cement or proprietary sealing system.

8.6.6 All block paving shall be sealed on completion with a proprietary sand stabilisation material.

S9 Kerbs and Channels

9.1 Kerb Race and Backing

9.2 Kerbs - General Requirements

9.3 Radius Kerb Lines

9.4 Blockwork Kerbs

9.1 Kerb Race and Backing

9.1.1 All kerb and channel Races are to be installed prior to the laying of the base course material.

9.1.2 Kerb Races shall be constructed using ST1 concrete to SHW Clause 2602 not less than 150mm thick and 425mm wide at the profile shown in Appendix E. The kerbs shall be backed with ST1 concrete.

9.2 Kerbs - General Requirements

9.2.1 Kerbs shall be laid to general regularity and with upstands indicated on the drawings contained within the Appendix drawings and in the requirements of BS7533. Current concerns regarding manual handling of precast concrete units shall be taken into account during the design and construction phases of the Development.

9.2.2 Where an asphalt surface course is employed, precast concrete kerbs shall be used. Such kerbs shall be

125mm x 255mm hydraulically pressed, granite Type HB2, half batter to BS EN 1340 and laid upright. Kerbs are to be bedded in mortar within 50mm of the face of the concrete beam, laid with dry joints and backed with ST1 concrete to a minimum thickness of 150mm, to within 50mm of the top of the kerb. Alternatively, the mortar bed may be omitted if the kerbs are laid on a beam that is still plastic.

9.2.3 No cut kerb shall be less than 300mm in length.

9.3 Radius Kerb Lines

9.3.1 For curves of radius 12.5m or tighter, the appropriate radius kerb shall be used.

9.3.2 The permission of the Director of Economy, Communities & Corporate is to be sought in all cases where it is proposed to use cut kerbs to achieve a smooth line on curves in excess of 12.5m. Cut kerbs shall be of equal lengths between 450 and 600mm and shall be suitably tapered cuts free of spalling to achieve a smooth front face of kerb.

9.4 Blockwork Kerbs

Blockwork kerbs are to be in accordance with the details indicated within the standard drawing appendix, bedded on grade ST1 Concrete.

S10 Gully Grates and Frames

10.1 General requirements

10.2 Spacing of Gullies

10.3 Ironwork within Cycleways/Footways

10.1 General Requirements

10.1.1 Gully gratings and frames shall be kite marked to BS EN 124:1994. Either cast steel or Ductile Iron may be used. The frames shall be bedded on a gauged Class 1 (3:1) sand/cement mortar and at least 2 courses (max 3 course) of Engineering Brickwork Class 'B' to BS EN 771-1. (Refer to standard detail in Appendix E).

10.2 Spacing of Gullies

10.2.1 Gully spacing is to be determined from the requirements of HA 102/00, Design Manual for Roads and Bridges.

10.3 Ironwork within Cycleways/Footways

10.3.1 All road gully gratings situated within cycleways, footways, shared surfaces etc shall be of a suitable Type approved by the Director of Economy, Communities & Corporate.

S11 Gully Pots

11.1 General Requirements - Type and Size

11.2 Bedding and Surround

11.1 General requirements - Type and Size (Refer to Standard Detail Appendix E)

11.1.1 Gully pots used for carriageway gullies shall generally be of precast concrete using Sulphate Resisting Cement (SRC).

11.1.2 Gully pots shall have internal dimensions 450mm diameter by 900mm deep and shall be of the trapped type unless otherwise directed by the Director of Economy, Communities & Corporate.

11.1.3 PVCu plastic gully pots (BBA Approved) of the above dimensions may be used at the discretion of the Director of Economy, Communities & Corporate. The typical detail of this type of gully installation shall incorporate suitable provisions to prevent the pots floating and distorting when the concrete surround is placed and compacted. The installation shall be entirely in accord with the BBA approval certificate requirements. The Director of Economy, Communities & Corporate would expect the BBA requirement to at least be equivalent to a concrete base slab provided below the pot bed and surround and which may take the form of a paving slab set on 100mm of ST2 concrete to SHW Clause 2602.

11.2 Bedding and Surround

11.2.1 Concrete gully pots shall be installed in accordance with BBA approval requirements. The pots are to be set on and surrounded by 150mm of ST2 concrete sulphate resistant cement to SHW clause 2602.

11.2.2 PVCu plastic pots shall be set on and surrounded by ST2 concrete. The surround shall be 200mm thick with a 100mm bed above the base slab in S11.1.3.

S12 Highway Drainage

12.1 General Requirements

12.2 Surface Water Pipes

12.3 Concrete Surround to Pipes

12.4 Soakaways

12.5 Prior to Adoption

12.1 General Requirements

It is usual that the Local Water Company under a section 104 agreement will adopt new drainage systems. Herefordshire Council will adopt the gullies and connections only in these circumstances subject to satisfactory installation.

12.1.1 Where no public stormwater sewer is proposed, an adequate piped highway surface water drainage system of approved pipe sizes; gradients and materials shall be provided to an outfall.

12.1.2 Highway surface water drains shall be laid in straight lines at uniform gradients between manholes. Sight rails shall be erected at intervals of no more than 45m and at changes of gradient.

12.1.3 Where an outfall drain or pipe unavoidably passes under land which will ultimately be conveyed to a dwelling, or which will ultimately remain undedicated as Highway, an Easement will be required giving the Highway Authority right of access at all times for the purpose of maintenance or repair. Acknowledgement of the presence of such a drain under each affected property must be safeguarded by the incorporation of a suitable Easement within the conveyance of that property by the Developer.

12.1.4 Where an outfall, drain ditch or pipe will discharge into an existing drain or pipe or watercourse not maintainable by the Local highway Authority, written evidence of the consent of the authority or owner responsible for the existing drain etc to such discharge shall be provided to the Director of Economy, Communities & Corporate.

12.1.5 No highway surface water outfall drain shall pass below any building.

12.1.6 Backfilling of pipe runs must be in accordance with S2.0.

12.2 Surface Water Pipes

12.2.1 The following types of pipe may be used for surface highway drains:

- Concrete pipes made with Sulphate resistant Cement
- PVCu twin walled with a smooth internal and ribbed external surface walls with current BBA certification
- Vitrified Clayware pipes

12.2.3 Jointing and installation shall be undertaken to Manufacturers Specification.

12.3 Concrete Surround to Pipes

12.3.1 All drainage runs irrespective of depth shall have a bed and surround of 150mm of concrete grade ST4 WITH sulphate Resistant Cement to SHW clause 2602.

12.3.2 In the case of plastic pipes care should be taken to ensure that the pipes do not float when the concrete is placed.

12.3.3 To maintain a degree of flexibility 13mm fibreboard (flexcel) or otherwise approved shall be placed at the pipe joints to the full width of the concrete surround.

12.3.4 For porous pipes the surround shall comprise of at least 150mm of no fines concrete to SHW Clause 2603.

12.4 Soakaways

12.4.1 Soakaways will not be allowed on new Developments unless all other courses of action have been eliminated. The Director of Economy, Communities & Corporate must approve their use prior to their inclusion within the Development. (Refer to Standard Detail in Appendix E).

12.5 Prior to Adoption

On the completion of the works and also prior to adoption, all drains, manholes, gullies etc., shall be cleaned out, flushed, and left free from all obstructions to the satisfaction of the Director of Economy, Communities & Corporate. Power cleaning may be required.

SI3 Manhole Covers and Frames

13.1 General Requirements

13.2 Bedding

13.1 General Requirements

(Refer to Standard Details in Appendix E)

13.1.1 All manhole covers and frames intended to be used within the Highway shall be kite marked products to BS EN 124, 1994 and badged S.W. (Surface Water) and F.W. (Foul Water)

13.1.2 The following additional requirements are to be met

- In carriageways and trafficked footways/Cycleways - Heavy Duty: BS EN 124 reference D400 with a clear opening of 600mm and minimum frame and cover depth of 150mm.
- In footways/Cycleways and verges - Medium Duty: BS EN 124 reference C250 with a clear opening of 400mm.

13.2 Bedding

13.2.1 The frames shall be bedded on a gauged Class I sand/cement mortar to DfT SHW Clause 2404 above two to three courses of Engineering Brickwork Class B.

13.2.2 Alternative bedding materials may be permitted but will require the approval of the Director of Economy, Communities & Corporate prior to commencement.

SI4 Headwalls

14.1 General Requirements

14.1 General Requirements

14.1.1 All pipe inlets or outlets to or from open watercourses must be provided with a headwall incorporating any necessary apron, scour baffle, handrails or other works. Suitable designs must be submitted to the Director of Economy, Communities & Corporate for approval. A suitable Design is included within Appendix E.

14.1.2 In certain locations, and with the approval of the Environment Agency, flap valves may be required. Flap valves should be made of heavy duty plastic (low maintenance type) or other approved by the Director of Economy, Communities & Corporate.

14.1.3 The invert level of the outlet pipe through the headwall shall be subject to scrutiny and approval by the Director of Economy, Communities & Corporate to ensure satisfactory flow through the drainage system.

14.1.4 Where headwalls are located within 6m of the footway, cycleway or carriageway they shall be provided with pedestrian safety railings to the requirements of the Director of Economy, Communities & Corporate.

S15 Footways/Cycleways

15.1 Preparation

15.2 Footway/Footpath/Cycleway - Base

15.3 Footway/Footpath/Cycleway - Binder Course

15.4 Footway/Footpath/Cycleway - Surface Course

15.5 Crossfall

15.6 Edge Supports

15.1 Preparation

15.1.1 The formation of the footway/footpath/Cycleway shall be levelled and compacted with a vibrating roller or other approved suitable item of plant to a properly shaped, even and uniform surface. Reference should be made to Appendix C1, C2, C3, C4 and C5, Compaction plant.

15.1.2 The formation shall be treated with an approved Weedkiller before construction commences. Only trained and certificated operatives will be permitted to use weed killers.

15.1.3 Bituminous materials shall be machine laid; where the Director of Economy, Communities & Corporate has given his approval small areas may be permitted to be hand laid.

15.2 Footway/Footpath/Cycleway - Base

15.2.1 The material used shall be granular sub base material Type I SHW clause 803. The thickness shall be 150mm.

15.3 Footway/Footpath/Cycleway - Binder Course

15.3.1 The Footway/Footpath binder course shall be 75mm compacted thickness AC 20 dense bin 100/150 rec to DfT MCHW Clause 906.

15.4 Footway/Footpath/Cycleway - Surface Course

15.4.1 The Footway/footpath surface course shall be 25mm compacted thickness AC 6 dense surf 100/150 to DfT MCHW Clause 909.

15.4.2 An examination of the surface course will be undertaken prior to adoption to ascertain prevalent defects. Any defects are to be rectified at the Developers expense.

15.4.3 Guidelines for delivery and rolling temperatures are given within Appendix D.

15.5 Crossfalls

15.5.1 The final footway surface shall have a Crossfall of 1:40 towards the carriageway.

15.6 Edge Supports

15.6.1 Where a footway does not abut a kerb or boundary wall a 50mm x 150mm hydraulically pressed, precast, flat topped, concrete edging to BS EN 1340 Type EF, shall be provided.

15.6.2 The precast edging must be securely bedded on a foundation of ST1 concrete SHW Clause 2602 - a minimum of 200mm deep and 200mm wide. It shall be backed with ST1 concrete from the back of the bedding to within 50mm (minimum 40mm) from the top of the edging.

S16 Vehicular, Pedestrian and Cycle Crossings

16.1 Vehicular Crossings

16.2 Pedestrian Crossings

16.3 Cycle Crossings

16.4 Construction Depths

16.5 Dropped Kerbs and Alignments

16.1 Vehicular Crossings

16.1.1 Vehicular crossings are to be provided at the entrances to all garages and residential properties with sufficient width to accommodate a vehicle.

16.1.2 A minimum of four precast concrete kerbs 125mm x 150mm to BS EN 1340 Type BN, shall be installed to provide a vehicular crossing with a minimum width of 3.6m. These dropped kerbs shall be set to show an upstand of 25mm with tolerances as given in G29.4.

16.2 Pedestrian Crossings

16.2.1 Where pedestrian routes cross carriageways and footways at junctions, two dropped kerbs with tapers shall be provided on each side of the carriageway or junction. Stick on Tactile paving shall be installed in accordance with the Drawing Appendix.

16.2.2 The dropped kerb shall be set +3mm with the carriageway channel level to the tolerances given in G29.4.

16.3 Cycle Crossings

16.3.1 Where a cycleway adjacent to the carriageway is interrupted by pedestrian or vehicular crossings, the change in

level shall be achieved over at least two kerbs, using standard precast concrete kerbs and laid to suit in place of the standard one taper kerb.

16.3.2 The dropped kerb shall be set +3mm with the carriageway channel level to the tolerances given in G29.4.

16.4 Construction Depths

16.4.1 Residential and light industrial or commercial vehicular access shall be constructed in accordance with the details indicated within the Standard Drawings (Appendix E).

16.4.2 For Heavy Goods Vehicles the construction shall be as per Standard Road Specification.

16.5 Dropped Kerbs and Alignments

16.5.1 Dropped kerbs and tapers shall comply with the requirements of BS EN 1340.

16.5.2 Kerbs shall be laid to a flowing alignment and to the construction requirements of S9 of this Specification.

16.5.3 Where the interval between adjoining vehicular crossings is such that less than three kerbs show the full face of 125mm the intervening kerbs between these crossings shall also be 125mm x 150mm laid to show an upstand of 25mm. The footway and/or cycleway between the crossings in this case shall also be constructed to vehicular access standards.

S17 Verges and Visibility Splays

17.1 Seeding and Turfing

17.2 Initial Ground Preparation

17.3 Fertilizer Application

17.4 Seeding

17.5 Turfing

17.6 Maintenance of Seeded Areas

17.7 Maintenance of Turfed Areas

17.8 Overseeding

17.9 Edge Support Delineation

17.1 Seeding and Turfing - General

The Developer shall carry out all work in the Specification in accordance with BS 7370 General Landscape Operation or a Standard approved by the Director of Economy, Communities & Corporate.

17.2 Initial Ground Preparation

The topsoil shall be cultivated to a depth of 125mm avoiding

the disturbance of the subsoil, by suitable approved mechanical means or by hand cultivation on banks or confined areas. All stones over 25mm in any dimension, weeds, roots and other undesirable material shall be removed from the Location and disposed of at an approved Refuse Disposal Site.

Soil shall be brought to a friable tilth by treading, firming and raking. Where applicable the degree of accuracy in determining a level profile shall be determined by boning rods, or other approved means, after firming in accordance with BS 7370.

Operations shall not be carried out during periods of inclement weather where the ground is saturated, boggy or frost covered.

17.3 Fertilizer Application

After final grading all areas to be seeded or turfed shall have a base dressing of an approved granular pre-seeding fertilizer applied at the rate of 50g per sq.m. The dressing shall be applied by means of approved fertilizer distributor machinery or by hand in small confined areas and then lightly worked into the surface with harrow or rake.

The final level for seeding shall be 50mm above any adjacent hard surface area and shall be flush with any adjacent hard surface for turfing.

17.4 Seeding

After cultivation operations have been carried out, the areas shall be sown with grass seed, which has been stored off the ground in a clean, dry place free from vermin. The Developer shall be required to supply Certificates for all grass seed stating the source, mixture, percentage, percentage purity and percentage germination rate and date of purchase.

The Director of Economy, Communities & Corporate will be entitled to take samples of the grass seed mixture for testing. The seed mixture shall meet the requirements of germination and purity laid down in BS 7370.

Following an even distribution of seed, the developer shall carry out a light raking or harrowing of the area and ensure consolidation of the seed with the soil by the use of a light roller.

All reasonable precautions shall be taken to ensure that pedestrians and other traffic does not cross areas during cultivation or until the grass is established.

17.5 Turfing

After cultivating operations have been carried out, the areas shall be laid to turf, a sample of which has previously been approved by the Director of Economy, Communities & Corporate.

Turf shall be to a uniform size and thickness from an approved supplier. It shall be laid with the use of boards in order that the Developer does not allow the previously laid grass to be walked on. All turf laid down shall be firmed with a wooden turfing hammer to give a uniform even area finishing 25mm above the edge of any adjacent hard area. Turf shall be laid in broken joints in a half band pattern.

All turf shall be laid within 24 hours of delivery from the supplier and shall not be damaged or yellowed.

Following turf laying an approved top dressing shall be spread and brushed over the turfed area ensuring all joints are adequately filled. To prevent scorching and shrinkage the turf shall not be allowed to dry out during establishment.

17.6 Maintenance of Seeded Areas

During the Spring following seeding, and before the application of any selective Weedkiller, the grassed area shall be dressed with an approved granular postseeding fertilizer applied at the rate of 50g per sq.m.

During the period of establishment, all newly grassed areas shall be cut twice, each cut reducing the growth height by one third. The first and second cuts shall take place when the growth height reaches 75mm. Seeded areas shall be lightly rolled to consolidate the surface one week prior to the first cut.

Cutting is to take place using suitable mowing machinery when conditions are not excessively wet or damp. Cutting shall be continued at appropriate intervals until the finished maximum height is 25mm.

17.7 Maintenance of Turfed Areas

During the Spring following seeding, and before the application of any selective Weedkiller, the grassed area shall be dressed with an approved granular postseeding fertilizer applied at the rate of 50g per sq.m.

During the period of establishment, all newly grassed areas shall be cut twice, each cut reducing the growth height by one third. The first and second cuts shall take place when the growth height reaches 75mm.

Cutting is to take place using suitable mowing machinery when conditions are not excessively wet or damp. Cutting shall be continued at appropriate intervals until the finished maximum height is 25mm.

During the period of establishment the Developer shall water the turf as often as necessary to ensure it does not dry out prior to establishment.

17.8 Overseeding

When instructed by the Director of Economy, Communities & Corporate, the Developer shall oversee sparse or thin areas of turf. The turf shall be overseeded using suitable and appropriate cultivars of grass seed approved by the Director of Economy, Communities & Corporate at the rate of 35g per sq.m. The surface shall be graded or topsoiled as necessary to provide even running levels and a surface suitable for seeding.

17.9 Edge Support Delineation

Edge support delineation through vehicular, pedestrian crossing points and around street lighting columns shall be provided by the installation of 50mm x 150mm Hydraulically-pressed, precast, flat topped, concrete edgings to BS EN 1340 Type EF.

S18 Street Lighting

18.1 Code of Practice

18.2 British Standards

18.3 Equipment

18.4 Installation

18.5 Painting/Numbering

18.6 Wiring

18.7 Earthing

18.8 Electrical Testing

18.9 Completion Certificates

18.10 Electricity Services

18.11 Connection to Supply

18.12 Reinstatement

18.13 Maintenance and Taking Over

18.1 Code of Practice

Workmanship and materials shall comply with the current Code of Practice for the Erection of Street Lighting Equipment (published by the Association of Street Lighting Contractors), the current Code of Practice for Electrical Safety in Public Lighting operations (published by the Institution of Lighting Engineers) and the current Department for Transport Specification for Highway Works.

18.2 British Standards

All materials or equipment shall comply with the current relevant British Standards whether or not it is referred to specifically in this document.

18.3 Equipment

Details of columns, lanterns etc., will be separately specified for each development.

18.4 Installation

18.4.1 The Developer is to supply, erect and install the whole of the equipment as specified in the agreement, together with any material which may not be expressly specified, but which is necessary for the satisfactory completion of the installation. Only specialist Street Lighting Contractors shall be employed on installation works. They shall be members of the Association of Street Lighting Electrical Contractors and registered on the Role of Approved Electrical Contractors by the National Inspection Council for Electrical Installation Contractor. The Engineer will require evidence of this. A list of Approved Electrical Contractors is available on request.

18.4.2 Each hole for a lighting column shall be dug by hand to the planting depth recommended by the manufacturer and in accordance with Appendix E.

18.4.3 Each column is to be fixed firmly and vertically on a prepared concrete foundation of ST4 grade concrete not less than 75mm thick, and shall be encased by 150mm minimum thickness of ST5 grade concrete complying with Clause 2602 in the Department of Transportation Specification for Highway Works, to finished ground level (see standard detail, Appendix E). A chase or 50mm dia. Duct shall be formed/provided at the time the concrete backfill is poured to allow entry of the electricity supply service cable.

18.4.4 Lanterns (and brackets if required) shall not be attached to the columns until 48 hours after placing concrete backfill.

18.4.5 Installation and commissioning is to be carried out as the development proceeds and in accordance with the needs of the residents and the main Contractor. In order that the positions for columns can be correctly established it is advisable that this should be done after the kerbs and/or edgings are laid and preferably before any paving is carried out.

18.4.6 Where provisional positions are shown on the approved street lighting layout drawings, they are to be adhered to wherever possible, and columns will normally be sited not less than 1 metre or more than 3 metres from kerb edge. Care should be taken to ensure that wherever possible columns are not installed directly in front of windows.

18.4.7 If doubt exists over the interpretation of the position or site conditions make proposed position impractical, alternative positions may be agreed with the Director's Representative, whose decision shall be final on all matters relating to siting of lamps.

18.4.8 A period of seven days notice is required by the Director's Representative if such action is considered necessary.

18.5 Painting/Numbering

18.5.1 Where painting is required, a separate specification will be issued but in all cases identification numbers will be detailed on the approved street lighting layout drawings.

18.5.3 The numbers will be black in colour, 50mm high and painted on a prepared painted yellow background. The yellow background shall be 100mm wide and 25mm longer than the total length of the numbers. The numbers shall be painted down the column shaft approximately 2m above ground level, positioned facing the carriageway.

18.6 Wiring

18.6.1 Wiring shall comply with the requirements of BS7671 (the 16th Edition of IEE Regulations).

18.6.2 The Developer shall provide for the complete supply and installation of wiring within the assembly down to the Electricity Company cut-out (allowing minimum of 600mm length tails for connection into cut-out).

18.6.3 The cables shall be single core copper, PVC insulated and grey sheathed 600/1000V rating to BS6004 except earth continuity conductor which shall be PVC insulated only.

18.6.4 Composite cables, which include an earth continuity conductor, will NOT be permitted.

18.6.5 Minimum conductor sizes shall be as follows:

- a) PECU cable - 1.5mm²
- b) Earth continuity conductor - 2.5mm²
- c) Main earth conductor - 6.0mm² (or larger if required by the local electricity company)
- d) All other connections within assembly - 2.5mm²

18.6.6 Insulation shall be colour coded as follows:

- a) Earth continuity conductor - Yellow/Green
- b) All other connections within assembly;
 - line - red
 - neutral - black

18.6.7 Adequate protection must be taken to protect the cables from heat within the lantern canopy by means or protective sleeving and all wiring shall be carried out in a neat and workmanlike manner with all cables taped together every metre and cleated to the base board.

18.6.8 Where the assembly has an electricity company cut-out a lockable safety isolator, type Charles LSI-03/SF/PS fitted with a 6 amp cartridge fuse to BS88 shall be mounted on the column base board and connected between the control gear and Electricity Company cut-out.

18.6.9 Where a one part PECU is installed, a separate 1.5mm single PVC insulated and sheathed cable shall be provided; this shall be connected between the output terminal of the NEMA socket and the switch incorporated in the LSI-03/SF/PS unit.

18.7 Earthing

18.7.1 The whole of the installation shall be earthed in accordance with the requirements of BS7671 (the current IEE Regulations), to British Standard Code of Practice CPI013 'Earthing' and to the satisfaction of the local Electricity Company.

18.7.2 A brass earth terminal shall be fitted in the column adjacent to the service cut-out to terminate the earth conductor and shall be connected to the Electricity Company earth point.

18.7.3 A separate circuit protective conductor of not less than 2.5mm² cross sectional area shall connect all metal enclosures of all electrical components to the main earth terminal and the Developer shall ensure that a sound mechanical and electrical connection is made.

18.7.4 Where bolted connections are required, these conductors shall be terminated in accordance with

manufacturers instructions in correctly sized purpose made lugs, which shall be attached to the conductor core by crimping/swaging and such connections shall be made with non ferrous nuts, bolts and washers of the correct size, to be supplied by the Developer if not provided with the component.

18.7.5 All extraneous conductive parts shall be bonded to the main earth terminal using an equipotential bonding conductor of 6mm². cross sectional area increased if necessary to conform with the electrical company's requirements when the Lighting Unit is directly serviced by a Protective Multiple Earthing (PME) supply.

18.8 Electrical Testing

On completion of this work, the Contractor shall carry out an electrical test in accordance with Appendix B3.

18.9 Completion Certificates

Upon satisfactory completion of all the above works, a copy of the Electricity Company Certificate of Completion shall be submitted to the Electricity Company for each point of connection to the supply network, together with a drawing showing the precise location of the lighting unit(s) to be connected and a copy of these documents shall be forwarded to the Council.

18.10 Electricity Services

The Developer shall be responsible for the cost and provision of electricity services (including cutouts in the column bases) which will be carried out by the Midlands Electricity Company only upon receipt of payment in advance from the Developer.

18.11 Connection to Supply

The Actual connection to the electricity supply cut-out shall be undertaken only by the local Electricity Company's personnel, and the Developer must enter into an agreement with the Electricity Company for the provision and payment of energy costs incurred until the lighting is adopted by the Council upon issue of the Part 2 Certificate.

18.12 Reinstatement

Where any reinstatement of road or footpath surfaces is required within the limits of the development this will be the responsibility of the Developer. Where, however, any openings are made in publicly maintainable highways, all works must comply with the arrangements specified in the new Roads and Street Works Act. When such openings have been made, the Developer will be held fully responsible for traffic management, lighting, watching and permanent reinstatement to the satisfaction of the Director and in accordance with the requirements of the Act.

18.13 Maintenance and Taking Over

18.13.1 The Developer shall remain responsible for the cost and provision of all energy and maintenance of the lighting units

prior to the issue of the Part 2 Certificate and must commission street lighting as the development proceeds.

18.13.2 The Council will only agree to take over the street lighting for energy and maintenance costs on issue of the Part 2 Certificate.

18.13.3 The Council will adopt the installation only if all materials and workmanship meet the specification and are to the entire satisfaction of the Director.

18.13.4 Immediately prior to the issue of the Part 2 Certificate, the Developer shall place an order with the Council's Street Lighting Maintenance Contractor (copy order to the Director) to have all lighting points included in the highway adoption inspected, the lanterns cleaned, new SOX Plus lamps fitted where low pressure sodium is used, all equipment checked for correct operation, and rectified if required. The cost of this work shall be the responsibility of the Developer and the Director shall be notified when the above works have been completed, so that a Part 2 Inspection may be carried out.

18.13.5 If the Part 2 Inspection reveals faults or omissions then the Director shall make good such defects at his own expense and shall notify the Director when a further Part 2 Inspection may be carried out (for which a charge may be made).

18.13.6 Following issue of the Part 2 Certificate, all energy and maintenance costs will become the responsibility of the Council.

S19 Street Nameplates

Note: Local variations to this Specification may apply in certain areas, such as Conservation areas. The Council is developing alternative specifications for use where the standard specification would be inappropriate. The Developer should seek guidance and approval from the Council before use of this specification in areas where it would be incompatible with the local style and character of street furniture. The following information is to serve as guide to Developers with regards to materials and workmanship.

- Aluminium plate with Class I reflective signface with channels and clips. Signface to have protective film applied to seal lettering;

Kindersley lettering in capitals - x height + 62.5mm
'No Through Road' sign (Diag 816.1 - TSRGD) where applicable

- Sign to be fixed to 1.5m plain tubular galvanised steel posts (60mm or 75mm dia). Posts are to be set in concrete 600mm below ground level;

- Signs are to be black lettering on white signface with a black border;
- Signs must be located within an area to be adopted as public highway (or existing public highway) and should be fixed as near as possible to street corners, so as to be easily readable by drivers as well as pedestrians. If in doubt, the position should be agreed on site with the Supervising Officer;
- Street nameplates should be mounted so that the top edge of the plate is approximately 1 Metre above the ground;
- Where numerous cul-de-sacs have the same name, house numbers should be incorporated as supplementary plates (contact the supervising officer in these cases); and
- See DOT Circular Roads 3/93 for more guidance.



Appendix AI - Construction Thicknesses

Standard Road Construction

	Nom. Size	Materials	Compacted Thickness
Surface Course	10mm	High Stone Content/Hot Rolled Asphalt – HSC/HRA 55/10 F Surf 40/60 des minimum PSV 55, to DfT SHW 911	40mm
Binder course	20mm	AC20 dense bin 100/150 rec to DfT SHW 906	60mm
Base Course	32mm	AC32 dense base 100/150 rec to DfT SHW 906	130mm in 2 Layers
Sub-base and Capping	CBR 5% and Above	Type 1 sub base to DfT SHW Clause 803	225mm
	2% - 5%	Type 1 sub base DfT SHW to Clause 803 6F1 or 6F2 Capping Layer to SHW Clause 613	150mm 350mm
	Below 2%	Type 1 sub base DfT SHW to Clause 803 6F1 or 6F2 Capping Layer to SHW Clause 613	150mm 600mm

Block Paved Roads

	Nom. Size	Materials	Compacted Thickness
Block Paving		Blocks to BS 7533-4 with jointing sand to BS7533	80mm
Sand Bedding		Laying sand to BS7533-4	30mm
Base Course	32mm	AC32 dense base 100/150 rec conforming to DfT SHW 906 – punctured at 1m centres for drainage	130mm in 2 layers
Sub-Base and Capping	CBR 5% and Above	Type 1 sub base conforming to DfT SHW Clause 803	225mm
	2% - 5%	Type 1 sub base SHW Clause 803 6F1 or 6F2 Capping Layer DfT SHW Clause 613	150mm 350mm
	Below 2%	Type 1 sub base SHW Clause 803 6F1 or 6F2 Capping Layer DfT SHW Clause 613	150mm 600mm

Cycleway/Footway Construction

	Nom. Size	Materials	Compacted Thickness
Surface Course	6mm	AC 6 dense surf 100/150 to DfT SHW Clause 909	25mm
Binder course	20mm	AC20 dense bin 100/150 rec conforming to DfT SHW 906	75mm
Sub-Base		Type 1 sub base conforming to DfT SHW Clause 803	150mm

Vehicular Crossings

	Nom. Size	Materials	Compacted Thickness
Surface Course	6mm	AC 6 dense surf 100/150 to DfT SHW Clause 909	25mm
Binder course	20mm	AC20 dense bin 100/150 rec conforming to DfT SHW 906	60mm
Base Course	32mm	AC32 dense base 100/150 rec to DfT SHW 906	100mm
Sub-Base		Type 1 sub base conforming to DfT SHW Clause 803 – Thickness may be increased depending on CBR values	150mm

Note:

Where the vehicular crossing serves other than for domestic use, the construction is to be as per carriageway.

Appendix B1 Testing to be carried out by the Contractor

- 1) This list is not exhaustive but covers the main items that will usually arise from the construction of Residential Roads. Concrete structures, buried corrugated steel structures, safety fencing etc will require additional testing.
- 2) Tests comparable to those specified in this appendix shall be undertaken for any equivalent work, goods or materials proposed by the Contractor (see sub clause 105.4 of the DfT SHW).
- 3) All testing will be carried out at the developer's expense.
- 4) (N) Indicates that a NAMAS test report or Certificate is required.
- 5) Unless otherwise shown in this Appendix tests for work, goods or materials as scheduled under any one Clause are required for such work, goods or materials in the works.
- 6) Where the Contractor uses work, goods or materials for which a testing schedule is not shown in Appendix B2 of the Specification, the Contractor shall use a test and frequency of test on the work, goods or materials as recommended by the Manufacturer and approved by the Director of Environmental Services.
- 7) Cube strengths shall not be required for concrete complying with BS 8500-1 Standard Mixes.

Appendix B2 Testing Program and requirements

Construction Stage	Testing Requirement	Supervision
Preliminary	Provide Geotechnical investigation and details of any recycled materials for Highway use	Prior to works commencing provide Herefordshire Council Supervising Officer with the following Details: <ul style="list-style-type: none"> ■ Site Manager ■ Site Telephone number ■ Out of hours telephone number ■ Principal contractor/groundworker ■ Developer ■ Planning Supervisor
Formation Level	CBR tests, quantity and location to be agreed with Supervising Officer	Supervising Officer to inspect/supervise
Capping/sub base level	Material Testing	Supervising Officer to inspect/supervise
Completion of sub base	Compaction Testing	Supervising Officer to inspect/supervise
Roadbase	Material Testing	Supervising Officer to inspect/supervise
Binder Course	Material Testing	Supervising Officer to inspect/supervise
Surface Course	Material Testing	Supervising Officer to inspect/supervise
Pipes for drainage and service ducts	Manufacturers Certificate of conformity	Supervising Officer to inspect/supervise
Pipe bedding	Material Testing	Supervising Officer to inspect/supervise
Filter media backfill	Material Testing	Supervising Officer to inspect/supervise
Precast concrete manhole chambers and ancillaries including covers	Manufacturers Certificate of conformity	Supervising Officer to inspect/supervise
Gullies (Precast concrete and plastic)	Manufacturers Certificate of conformity	Supervising Officer to inspect/supervise
Watertightness of joints	Air Test	Supervising Officer to inspect/supervise
Acceptable material	Material Testing	Supervising Officer to inspect/supervise
Surface regularity	Rolling straight edge	Supervising Officer to inspect/supervise
Unbound sub base material	Material Testing	Supervising Officer to inspect/supervise
Granular sub base material Type I	Material Testing	Supervising Officer to inspect/supervise
Precast kerbs, channels and edgings	Material Testing	Supervising Officer to inspect/supervise
Concrete block paving	Material Testing	Supervising Officer to inspect/supervise
Masonry cement (including sand, water, lime and admixtures)	Material Testing	Supervising Officer to inspect/supervise
Bricks and blocks	Manufacturers Certificate of conformity	Supervising Officer to inspect/supervise
Completion of works		Supervising Officer to inspect/supervise
Completion of 12 month maintenance period		Supervising Officer to inspect/supervise

Supervising Officer

The Supervising Officer shall be a nominated person of sufficient competency as defined within CDM Regulations

Material Testing

Where a material is required to be tested prior to being incorporated into the works, the exact testing requirements can be obtained from Herefordshire Council.

Appendix B3: Electrical Testing

The Contractor shall carry out the following tests and the results recorded: -

- (a) Visual inspection to establish condition of all components, wiring and terminations;
- (b) Verification of correct rating of protective device, continuity of protective conductors and earth bonding;
- (c) Polarity;
- (d) Insulation resistance between live/earth and neutral/earth with assembly wiring disconnected; and
- (e) Earth fault loop impedance at electricity company cut-out.

The method of testing shall be such that no danger to persons or property or damage to components can occur even if the circuit tested is defective. For a 'Satisfactory' result to be recorded, insulation resistance shall be measured at a test voltage of 500V to be not less than 1.0m ohm for Internal Wiring Tests.

The Contractor shall provide and submit a completed Test and Inspection Certificate acceptable to the Electricity Company in respect of all lighting units tested in accordance with the above.

All equipment used and work done shall comply with Statutory and other Regulations, Codes of Practice, and current British Standard Specification, principally as follows:

- (a) **Regulations**
 - i) The Institution of Electrical Engineers 'Regulations for Electrical Installations' Sixteenth Edition 1991
 - ii) The Electricity at Work Regulations 1989
- (b) **Codes of Practice**
 - i) Institution of Lighting Engineers Code of Practice for Electrical Safety in Public Lighting Operations : (Fourth Edition : 1993)
 - ii) CP 1013 : 1965 'Earthing' (BS)
- (c) **Department for Transport Requirements**
 - i) Specification for Highway Works, Part 4 : 1986
 - ii) Work within the Highway shall conform with Traffic Signs Manual Chapter 8 Traffic Safety Measures for Roadworks in Clauses 2.12, 2.13 and 2.14

Appendix C1: Earthworks, Sub-base and Trench Reinstatement

MATERIALS COMPACTION - SHEET I Definitions, Classification and General use of Earthworks Materials

The following definitions of earthworks materials shall apply to this and other Clauses of the Specification in which reference is made to defined materials:

- I. Topsoil shall mean the top layer of soil that can support vegetation
- II. Suitable material shall comprise all that which is acceptable in accordance with the Specification for use in the works.
- III. Unsuitable material shall mean other than suitable material and shall comprise:
 - 1. Material from swamps, marshes and bogs;
 - 2. Peat, logs, stumps and perishable materials
 - 3. Materials susceptible to spontaneous combustion
 - 4. Materials in a frozen condition
 - 5. Clay of liquid limit exceeding 90 and/or plasticity index exceeding 65
 - 6. Materials giving a moisture content greater than the maximum permitted for such materials in the Specification, unless otherwise permitted by the Director's Representative.

For the purpose of Appendix C3 Earthworks Compaction Table materials are grouped as follows:

- I. 'Cohesive soil' includes clays and marls with up to 20 percent of gravel or rock and having a moisture content not less than the level of the plastic limit (determined in accordance with BS 1377 Test No 3) minus 4; also chalk having a saturation moisture content of 20 percent or greater.
- II. 'Well graded granular and dry cohesive soils' includes clays and marls with up to 20 percent of gravel coefficient exceeding 10 and chalk having a saturation moisture content of 15-20 percent, well graded sands and gravels with a uniformity or rock and having a moisture content not less than the level of the plastic limit.
- III. 'Uniformly graded material' includes sand and gravels with a uniformity coefficient of 10 or less and all silts and pulverised fuel ashes. Any soil containing 80 percent or more of material in the particle size range 0.06-0.002mm will be regarded as silt for this purpose.
- IV. The Developer shall only employ that plant which is suitable to the soils that are to be handled. He shall take care to maintain the nature of the suitable material so that when it is placed and compacted it remains suitable in accordance with the Specification.

- V. Where the excavation reveals a combination of suitable and unsuitable material the Developer is advised to carry out the excavation in such a manner that the suitable materials are excavated separately for use in the works without contamination by the unsuitable materials.
- VI. Materials for use as sub base shall comply with the requirements of S6.2.
- VII. The compaction of sub base material shall meet the requirements of Appendix C4 Sub base compaction table.
- VIII. For the purposes of Appendix C5 Materials will be grouped as follows:
 - 1. Cohesive materials
 - 2. Granular materials
 - 3. Bituminous materials

These materials shall be strictly in accordance with the Specification. The compaction of the trench reinstatement materials shall meet the requirements of Appendix C5 Trench Reinstatement Compaction Tables.

Appendix C2: Compaction Plant

1. The depth of a compacted layer is the height by which the embankment is raised by each successive compacted layer.
2. The number of passes is the number of times that each point on the surface of the layer being compacted has been traversed by the item of compaction plant.
3. The compactive effort of each compactor is a function of the mass of the machine and the compaction plant in Appendices C3, C4 and C5 are listed in terms of their masses. Where a smooth wheeled roller has more than one axle the machine shall be assessed on the basis of the axle giving the lowest value of mass per metre width.
4. Vibrating rollers are self propelled or towed smooth wheeled rollers having a means of applying mechanical vibration to one or more rolls.
5. The requirements of vibrating rollers are based on the use of the lowest gear on a self propelled machine with mechanical transmission and a speed of 1.5-2.5 km/h for a towed machine or a self propelled machine with a hydrostatic transmission. If higher speeds or gears are used an increased number of passes shall be provided in proportion to the increase in speed of travel.
6. Where a mechanical vibration is applied to two rolls in tandem, the minimum number of passes shall be half the number given in the compaction tables (Appendices C3, C4 and C5) for the appropriate mass per metre width of one vibrating roll. If one roll differs in mass per metre width from the other, the number of passes shall be calculated as for the roll of the lower value. Alternatively, the machine may be treated as having a single vibrating roll with a mass per metre equal to that of the roll with the higher value.
7. Vibrating type rollers operating without vibration will be classified as smooth wheeled rollers.
8. Vibrating rollers shall be operated with their vibratory mechanism operating only at the frequency of vibration recommended by the Manufacturer. All such rollers shall be equipped or provided with a device automatically indicating the frequency at which the mechanism is operating.
9. Vibrating plate compactors are machines having a base plate to which is attached a source of vibration consisting of one or two eccentrically weighted shafts.
10. The mass per unit area of vibrating plate compactors is calculated by dividing the total mass of the machine in its working condition by the area of the plate on contact with the surface of the layer being compacted.
11. Vibrating plate compactors shall be operated at the frequency of vibration recommended by the Manufacturer. They shall nominally be operated at travelling speeds of less than 1 km/h but if higher speeds are necessary the number of passes shall be increased in proportion to the increase in speed of travel.
12. Vibro tampers are machines in which an engine driven reciprocating mechanism acts on a spring system through the oscillations set up in a base plate.
13. Where combinations of different type of categories of plant are used, the compaction requirements shall be:
 - The depth of layer shall be that shall be that for the type of plant required least depth of layer, and:
 - The number of passes shall be that for the type of plant requiring the greatest number of passes.
14. Where the Contractor uses a lighter type of plant to provide some preliminary compaction only to assist the use of heavier plant, this shall be disregarded in assessing the requirements of Appendix C3.
15. Where materials of widely divergent characteristics are used in embankments and fill area they shall be spread and compacted in separate clearly defined areas in such a manner as to comply with the requirements of Appendix C3.
16. If more than one Class of material is being used in such a way that it is not practicable to define the areas in which each class occurs, compaction plant shall be operated as if only the material which requires the greater compactive effort is required.
17. If in doubt about the choice of appropriate plant, the Developer should contact the Director's Representative.

Appendix C3: Earthworks Compaction Table

Type of Compaction Plant	Category	Cohesive Soils		Well Graded Granular and Dry Cohesive Soils		Uniformly Graded Material		
Smooth Wheeled Roller	Mass per metre width of roll Kg/m	D	N	D	N	D	N	
	Over 2100kg up to 2700kg	125	8	125	10	125	10	
	Over 2700kg up to 5400kg	125	6	125	8	125	8	
	Over 5400kg	150	4	150	8	Unsuitable		
Vibrating Roller	Mass per metre width of roll on a vibrating roller Kg/m	D	N*	D	N*	D	N*	
	Over 270kg up to 450kg	Unsuitable		75	16	150	16	
	Over 450kg up to 700kg	Unsuitable		75	12	150	12	
	Over 700kg up to 1300kg	100	12	125	10	150	6	
	Over 1300kg up to 1800kg	125	8	150	8	200	10	
	Over 1800kg up to 2300kg	150	4	150	4	225	12	
	Over 2300kg up to 2900kg	175	4	175	4	250	10	
	Over 2900 kg up to 3600kg	200	4	200	4	275	8	
	Over 3600kg up to 4300kg	225	4	225	4	300	8	
	Over 4300kg up to 5000kg	250	4	250	4	300	6	
	Over 5000kg	275	4	275	4	300	4	
	Vibrating Plate Compactor	Mass per unit area of base Kg/sq.m	D	N	D	N	D	N
		Over 880kg up to 1100kg	Unsuitable		Unsuitable		75	6
Over 1100kg up to 1200kg		Unsuitable		75	10	100	6	
Over 1200kg up to 1400kg		Unsuitable		75	6	150	6	
Over 1400kg to 1800kg		100	6	125	6	150	4	
Over 1800kg up to 2100kg		150	6	150	5	200	4	
Over 2100kg	200	6	200	5	250	4		
Vibro-Tamper	Mass	D	N	D	N	D	N	
	Over 50kg up to 65kg	100	3	100	3	150	3	
	Over 65kg up to 75kg	125	3	125	3	200	3	
	Over 75kg up to 100kg	150	3	150	3	225	3	
	Over 100kg	225	3	200	3	225	3	

D = Maximum depth of compacted layer

N = Minimum number of passes

Notes:

***For twin drum machines with both drums vibrating, halve the number of passes.**

If in doubt concerning machine rating contact the Director's Representative.

The majority of small vibrating plate compactors do not comply with the minimum requirements of this table and are therefore not suitable for sub base compaction.

Manufacturers plant should be checked against the Type and Category columns to determine their suitability and performance for a given material and layer thickness.

Appendix C4: Sub-Base Compaction Table

Type of Compaction Plant	Category	Number of passes for layers not greater than:	
		110mm	150mm
Smooth Wheeled Roller	Mass per metre width of roll Kg/m		
	Over 2700kg up to 5400kg Over 5400kg	16 8	Unsuitable 16
Vibrating Roller	Mass per metre width of roll on a vibrating roller Kg/m	*	*
	Over 700kg up to 1300kg	16	Unsuitable
	Over 1300kg up to 1800kg	6	16
	Over 1800kg up to 2300kg	4	6
	Over 2300kg up to 2900kg	3	5
	Over 2900 kg up to 3600kg	3	5
	Over 3600kg up to 4300kg	2	4
	Over 4300kg up to 5000kg Over 5000kg	2 2	4 3
Vibrating Plate Compactor	Mass per unit area of base Kg/sq.m		
	Over 1400kg to 1800kg	8	Unsuitable
	Over 1800kg up to 2100kg Over 2100kg	5 3	8 6
Vibro-Tamper	Mass kg		
	Over 50kg up to 65kg	4	8
	Over 65kg up to 75kg Over 75kg up to 100kg	3 2	6 4

Notes:

***For twin drum rollers with both drums vibrating, halve the number of passes.**

If in doubt concerning machine rating contact the Director's Representative.

The majority of small vibrating plate compactors do not comply with the minimum requirements of this table and are therefore not suitable for sub base compaction.

Manufacturers plant should be checked against the Type and Category columns to determine their suitability and performance for a given material and layer thickness.

Appendix C5: Trench Reinstatement Compaction Table

Compaction Plant and Weight Category	Cohesive Materials		Less than 20% granular content		Granular Materials		Greater than 20% granular content		Bituminous Materials		
	Compaction passes required/Layers compacted thickness up to:		Compaction passes required/Layers compacted thickness up to:		Compaction passes required/Layers compacted thickness up to:		Compaction passes required/Layers compacted thickness up to:				
Vibro-tamper 50kg minimum	100mm	150mm	200mm	100mm	150mm	200mm	40mm	60mm	80mm	100mm	
	4	8*	Unsuitable	4	8*	12	5**	7**	Unsuitable	Unsuitable	
Vibrating Roller 600-1000kg/m twin drum 1000-2000kg/m single drum 1000-2000kg/m twin drum 2000-3500kg/m single drum Over 2000kg/m twin drum Over 3500kg/m single drum	Unsuitable	Unsuitable	Unsuitable	6	Unsuitable	Unsuitable	5	7	Unsuitable	Unsuitable	
	Unsuitable	Unsuitable	Unsuitable	6	Unsuitable	Unsuitable	6	Unsuitable	Unsuitable	Unsuitable	
	Unsuitable	Unsuitable	Unsuitable	3	6	Unsuitable	4	5	6	8	
	Unsuitable	Unsuitable	Unsuitable	3	5	7	5	7	8	Unsuitable	
Vibrating Plates 1400-1800kg/sq.m Over 1800kg/sq.m	Unsuitable	Unsuitable	Unsuitable	5	Unsuitable	Unsuitable	6	Unsuitable	Unsuitable	Unsuitable	
	3	6	Unsuitable	3	5	7	4	5	6	8	
Notes:											
1) Single drum indicates vibration on one drum only											
2) Twin drum requires vibration on both drums											
3) Twin drum rollers are preferred for bituminous materials											
Minimum layer thickness of 75mm											
*These options are not allowed for use on wholly cohesive materials i.e. pure clay and/or silt containing no particle greater than 75 microns											
Minimum layer thickness 75mm											
Compaction should be discontinued if any distress to the material is noticed											
** A Vibro-tamper shall not be permitted for the compaction of the permanent surface course applied to trenches of greater than 500mm width											
Alternative plant for trenches less than 200mm width, small excavations and other areas of restricted access											
Vibro tamper 25kg minimum	6 passes minimum		6 passes minimum		6 passes minimum		6 passes minimum		6 passes minimum		
	Maximum layer size 100mm		Maximum layer size 100mm		Maximum layer size 100mm		Maximum layer size 100mm		Maximum layer size 75mm		
Percussive Rammer 10kg minimum											



CONSTRUCTION SPECIFICATION

Appendix D: Bituminous material delivery and rolling temperatures to be in accordance with BS 13108



Appendix E

Standard Drawings

Drawing Number	Description
001	Kerbing Detail A
002	Kerbing Detail B
003	Tactile Paving Detail
004	Typical Section Estate Road
005	Typical Section Shared Surface
006	Shared Surface Ramp Detail
007	New Carriageway Construction Keying Into Existing Works
008	Typical Gully Detail
009	Typical UPVC Gully Detail
010	Typical Manhole Type A
011	Typical Manhole Type B
012	Typical Manhole Type C
013	Soakaway Chamber
014	Typical Outlet Headwall
015	Street Lighting Column Groups 1 & 1A
016	Street Lighting Column Groups 2 & 2A
017	Street Lighting Column Foundation Details (Planted)
018	Highway Tree - Section
019	Highway Tree - Plan

CONSTRUCTION SPECIFICATION

Drawing 001: Kerbing Detail I

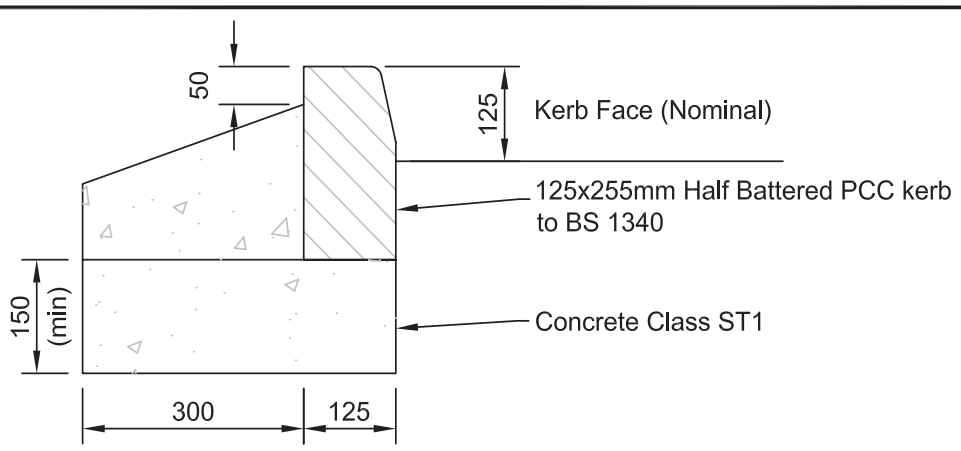

DETAIL A
CONCRETE KERB TYPE HB2

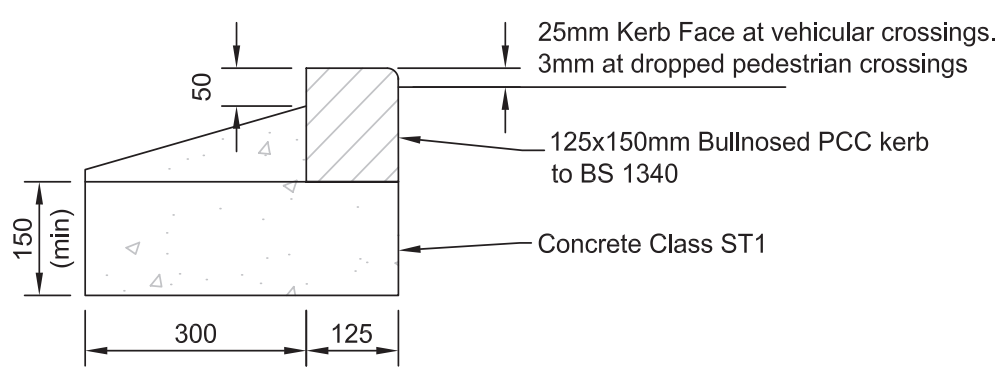

DETAIL B
DROPPED KERB TYPE BN

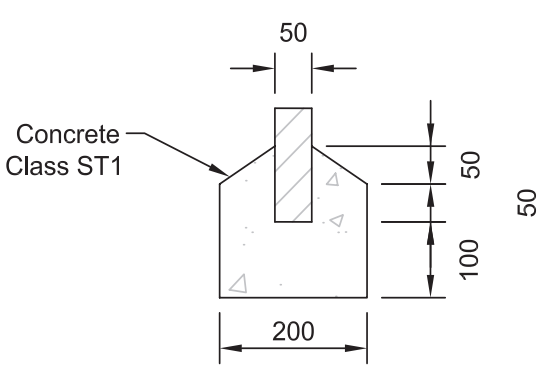

DETAIL C
FOOTWAY EDGING TYPE EF

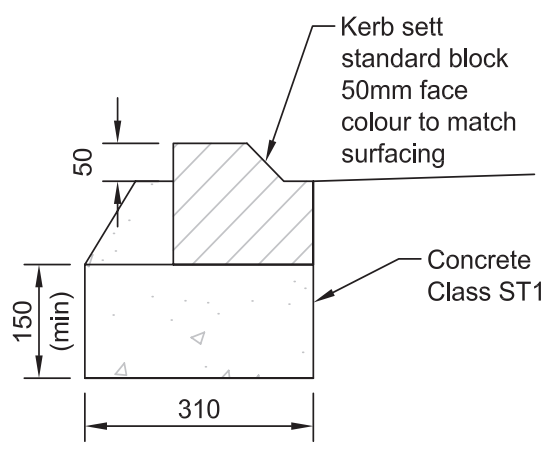

DETAIL D
**FOOTWAY EDGING -
BLOCK KERB**

Drawing 002: Kerbing Detail 2

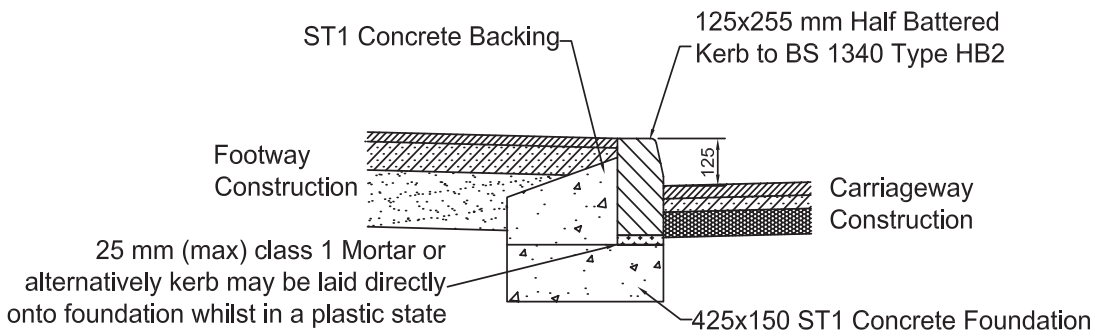

Kerb Detail - Footway to Road

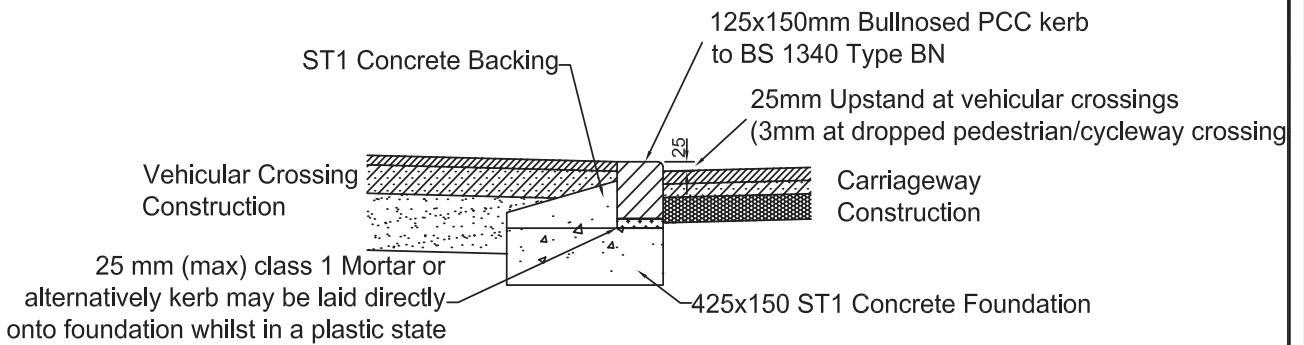

Kerb Detail - Vehicular Crossing to Road

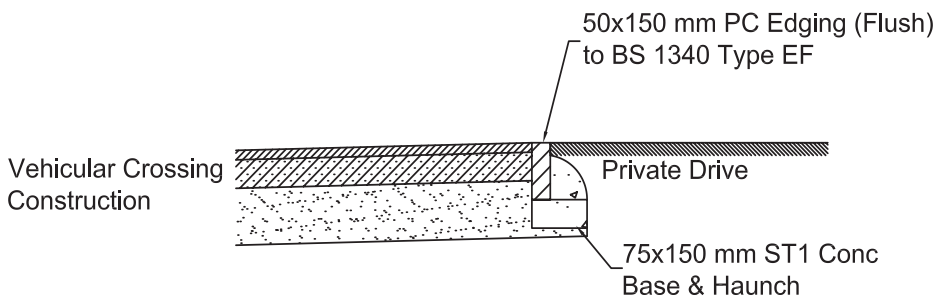

Edging Detail - Vehicular Crossing

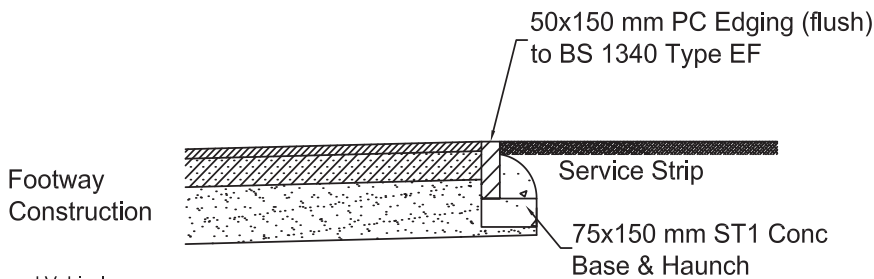

Edging Detail - Footway

NOTES

For details of Footway and Vehicular Crossing Construction please refer to Appendix A1 : Construction Thicknesses

CONSTRUCTION SPECIFICATION

Drawing 003: Tactile Paving Detail - Uncontrolled Pedestrian Crossing

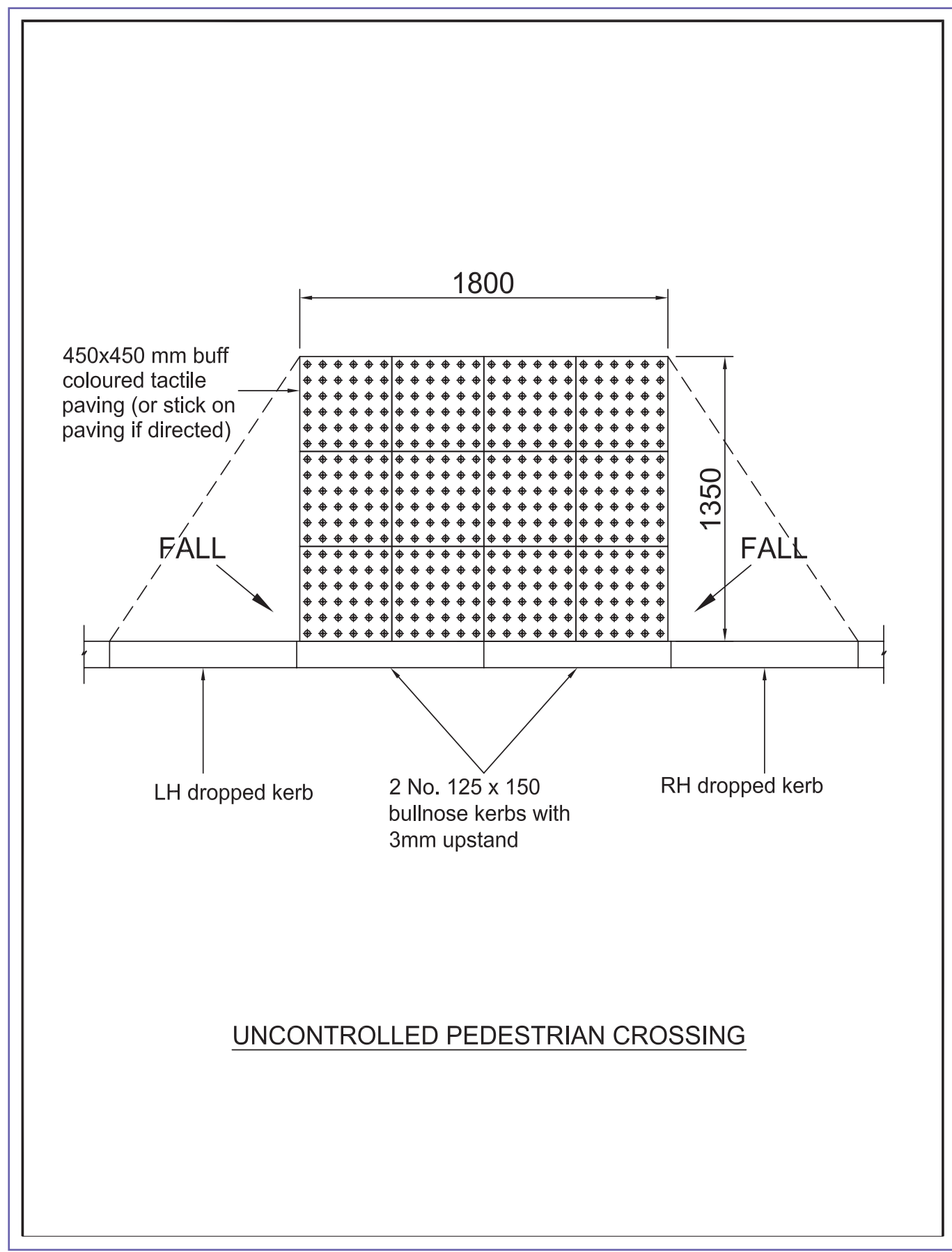

Drawing 004: Typical Section Estate Road

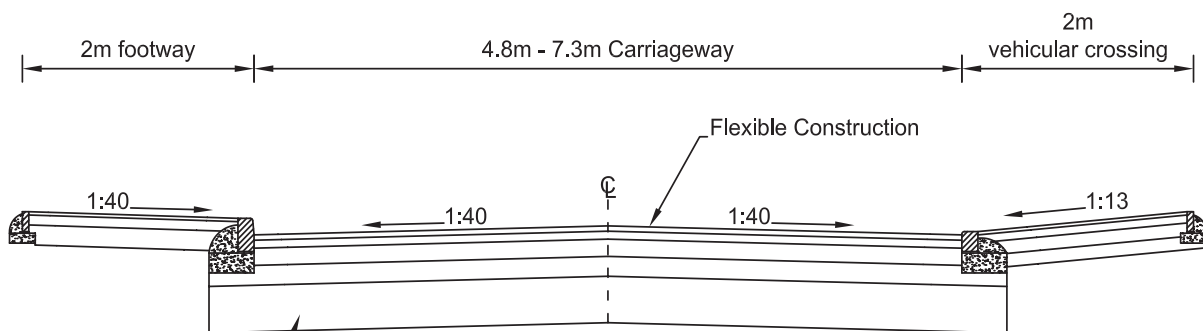

Capping Layer shown. Please refer to
Appendix A1 : Construction Thicknesses
for appropriate carriageway construction details

NOTES

For details of footway and vehicular crossing
construction please refer to Appendix A1 :
Construction Thicknesses

CONSTRUCTION SPECIFICATION

Drawing 005: Typical Section - Shared Surface

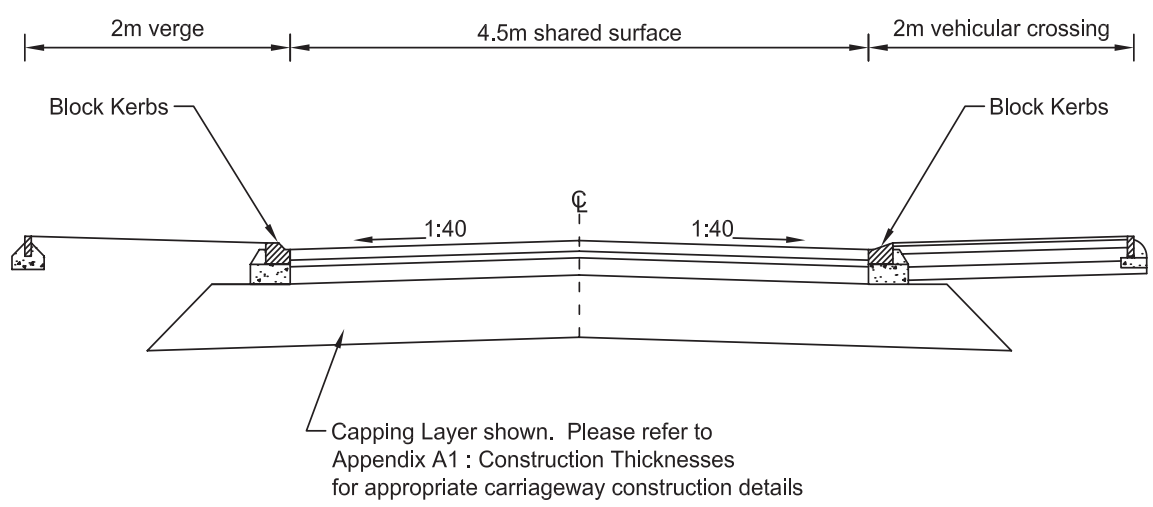

NOTES

For details of footway and vehicular crossing construction please refer to Appendix A1 : Construction Thicknesses

Drawing 006: Shared Surface Ramp Detail

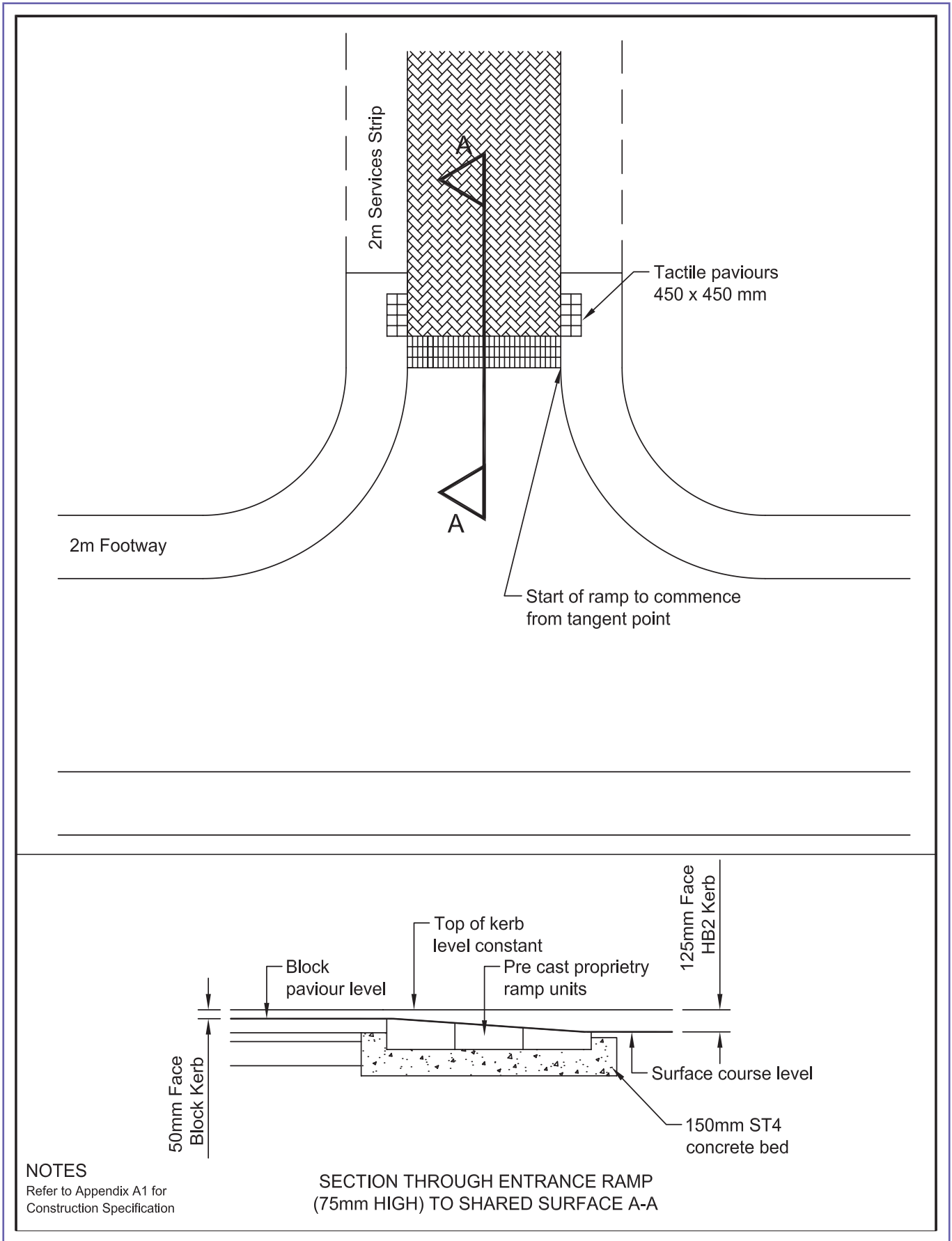

CONSTRUCTION SPECIFICATION

Drawing 007: New Carriageway Construction Keying into Existing Works

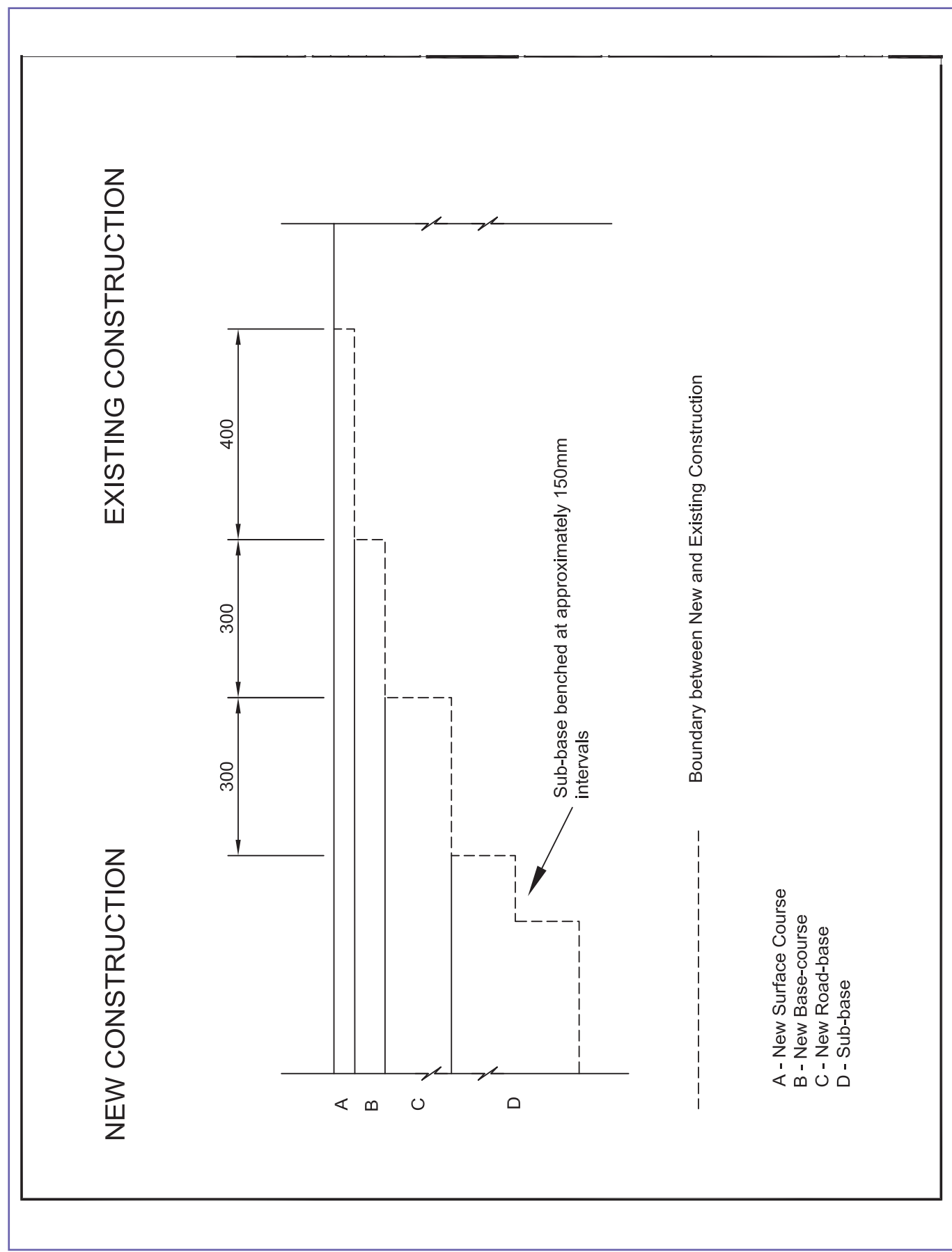

Drawing 008: Typical Gully Detail

BS EN:124(1994) Grade D400 rectangular double triangular gully grating and frame bearing CE approval mark.

All products must satisfy the following:-

- CE Mark
- BSEN 124
- ISO9001 design & manufacture assessed by 3rd party accredited to BSEN45012.
- Product testing by 3rd party accredited to BSEN45001 & having BSEN124:1994 within its registration.
- Certificates issued by 3rd party accredited to BSEN45011 & having BSEN124:1994 within its scope of registration.
- All 3 elements of the 3rd party assessed certification to be undertaken by a single organisation.

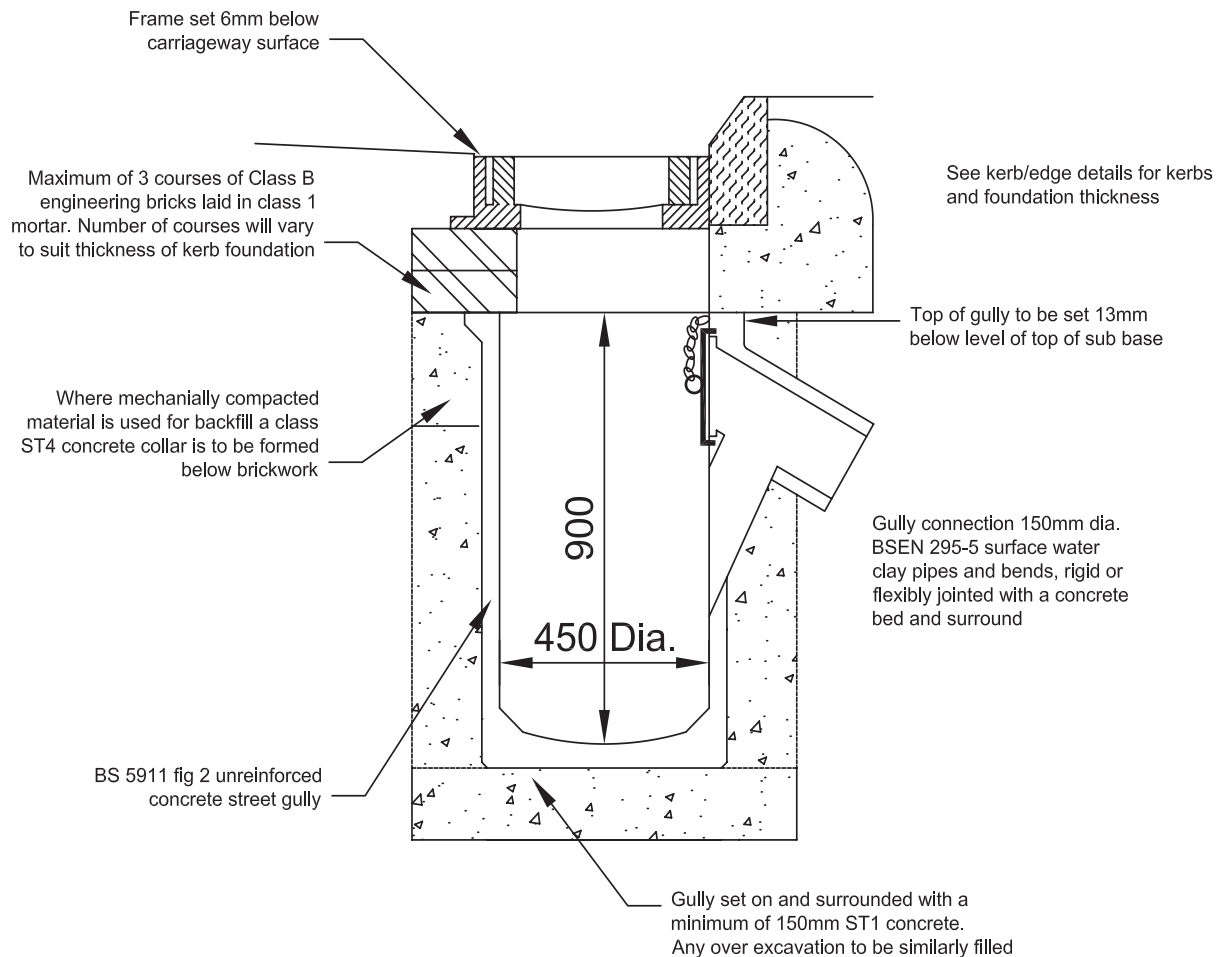

Drawing 009: Typical UPVC Gully Detail

BS EN:124(1994) Grade D400 rectangular double triangular gully grating and frame bearing CE approval mark.

All products must satisfy the following:-

- CE Mark
- BSEN 124
- ISO9001 design & manufacture assessed by 3rd party accredited to BSEN45012.
- Product testing by 3rd party accredited to BSEN45001 & having BSEN124:1994 within its registration.
- Certificates issued by 3rd party accredited to BSEN45011 & having BSEN124:1994 within its scope of registration.
- All 3 elements of the 3rd party assessed certification to be undertaken by a single organisation.

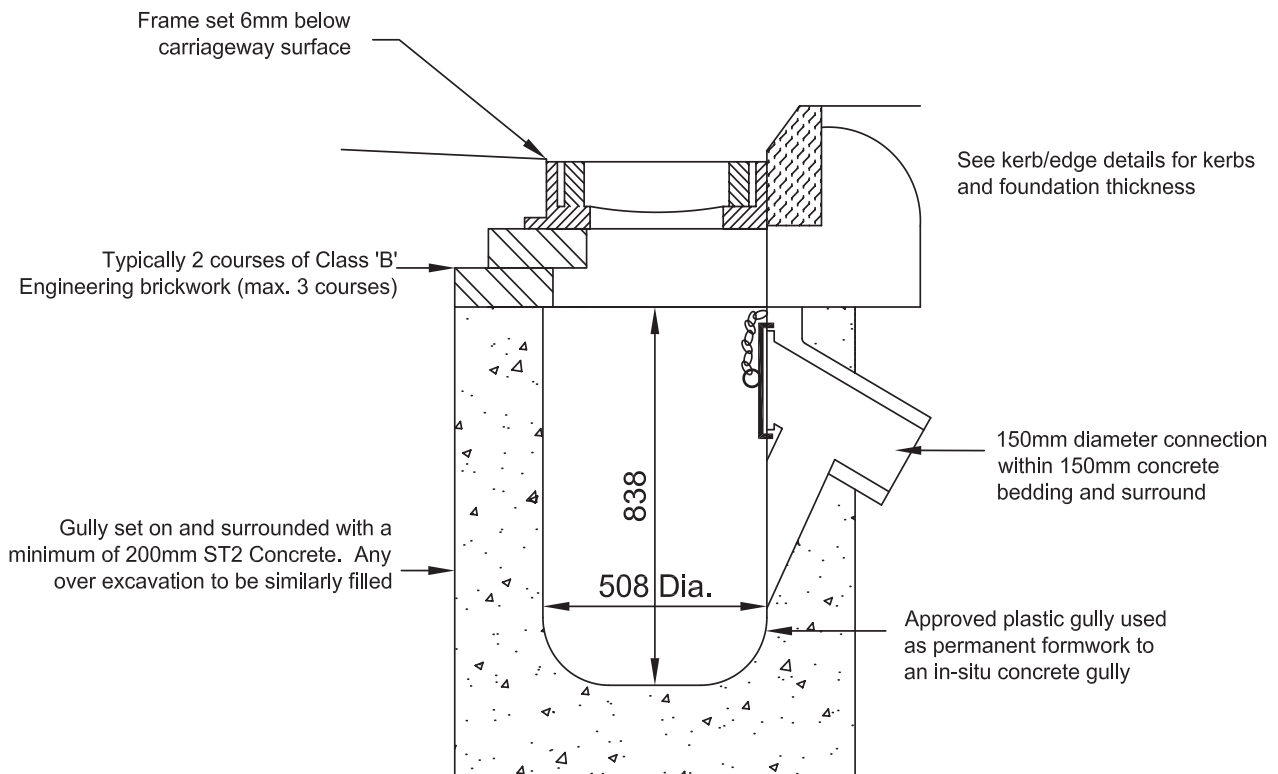

NOTES

1. Installation is to be in accordance with BBA approval certificate requirements.
2. Suitable provisions must be included to prevent the pots floating and/or distorting when the concrete surround is placed and compacted.

Drawing 010: Typical Manhole Type A

TYPICAL MANHOLE DETAIL - TYPE A
Depth to soffit 3m to 6m

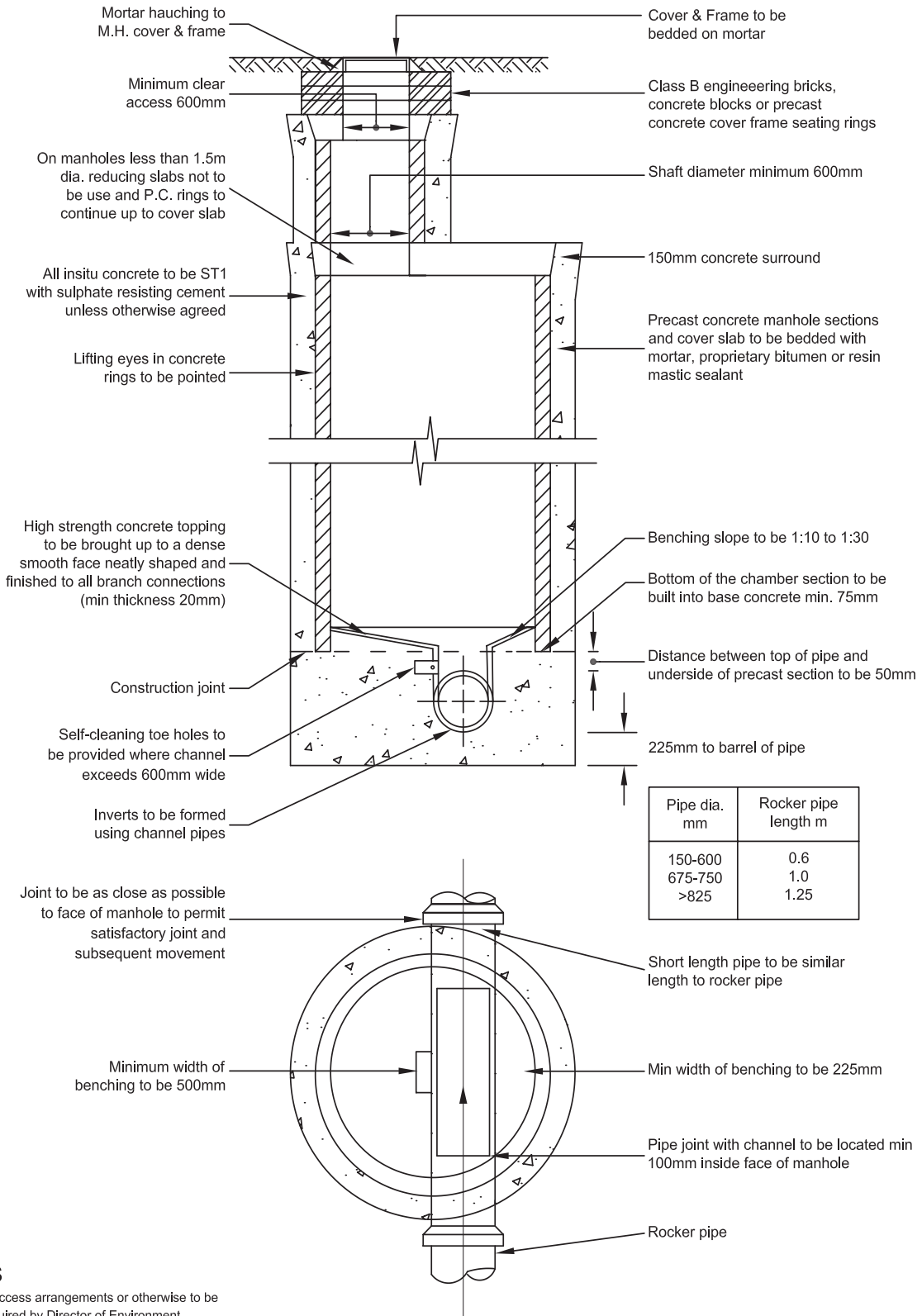

NOTES

Steps and access arrangements or otherwise to be fitted as required by Director of Environment.

CONSTRUCTION SPECIFICATION

Drawing 011: Typical Manhole Type B

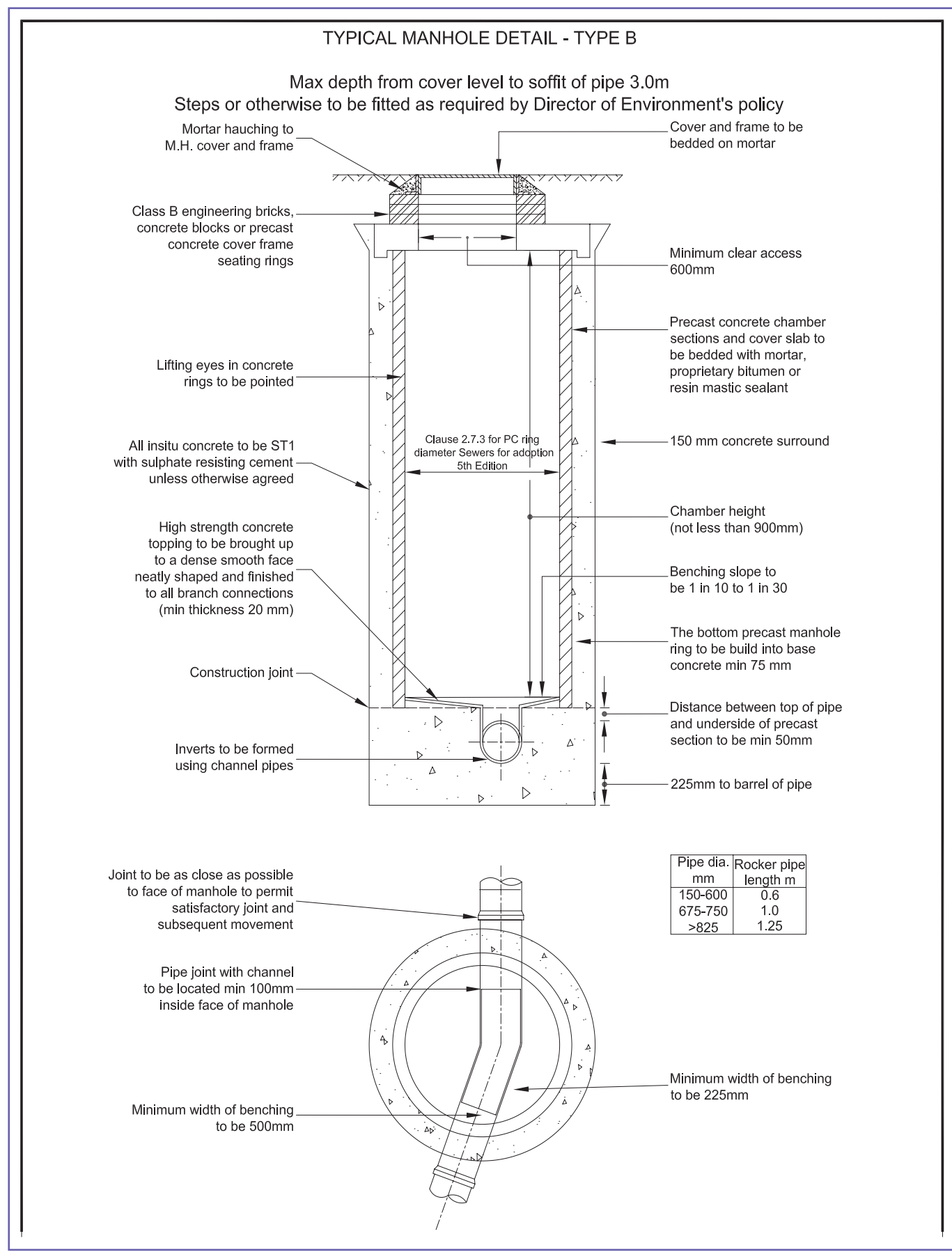

Drawing 012: Typical Manhole Type C

TYPICAL MANHOLE DETAIL - TYPE C

Depth from cover level to soffit of pipe 1.0m to 1.5m

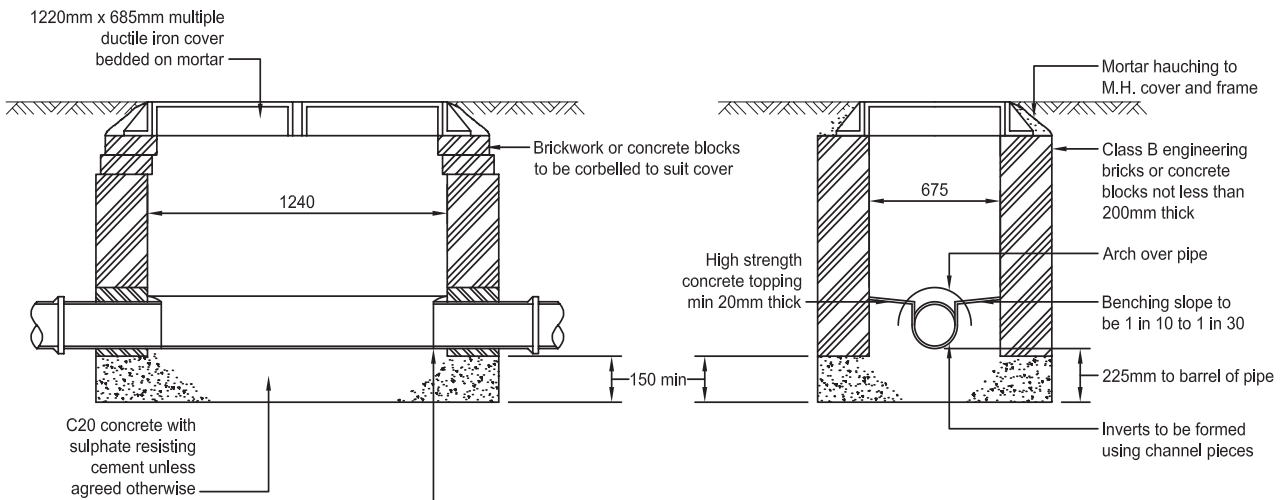

Internal dimensions of manhole normally 1240mm x 675mm but manhole width should be increased for pipes larger than 225mm dia to give 225mm benching each side and the brickwork/masonry units corbelled down to suit cover.

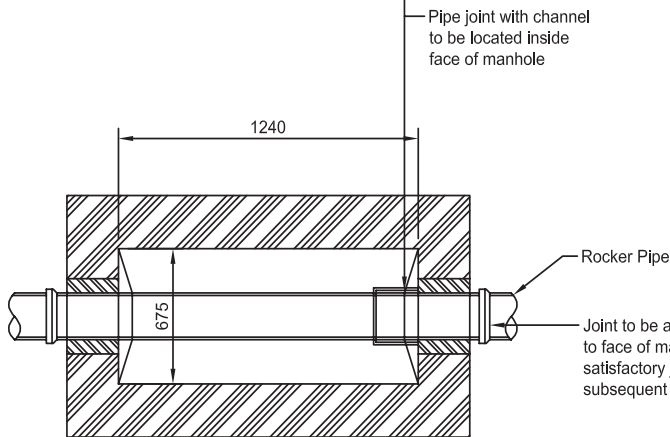

Pipe dia. mm	Rocker pipe length m
150-500	0.6
675-750	1.0
>825	1.25

CONSTRUCTION SPECIFICATION

Drawing 013: Soakaway Chamber

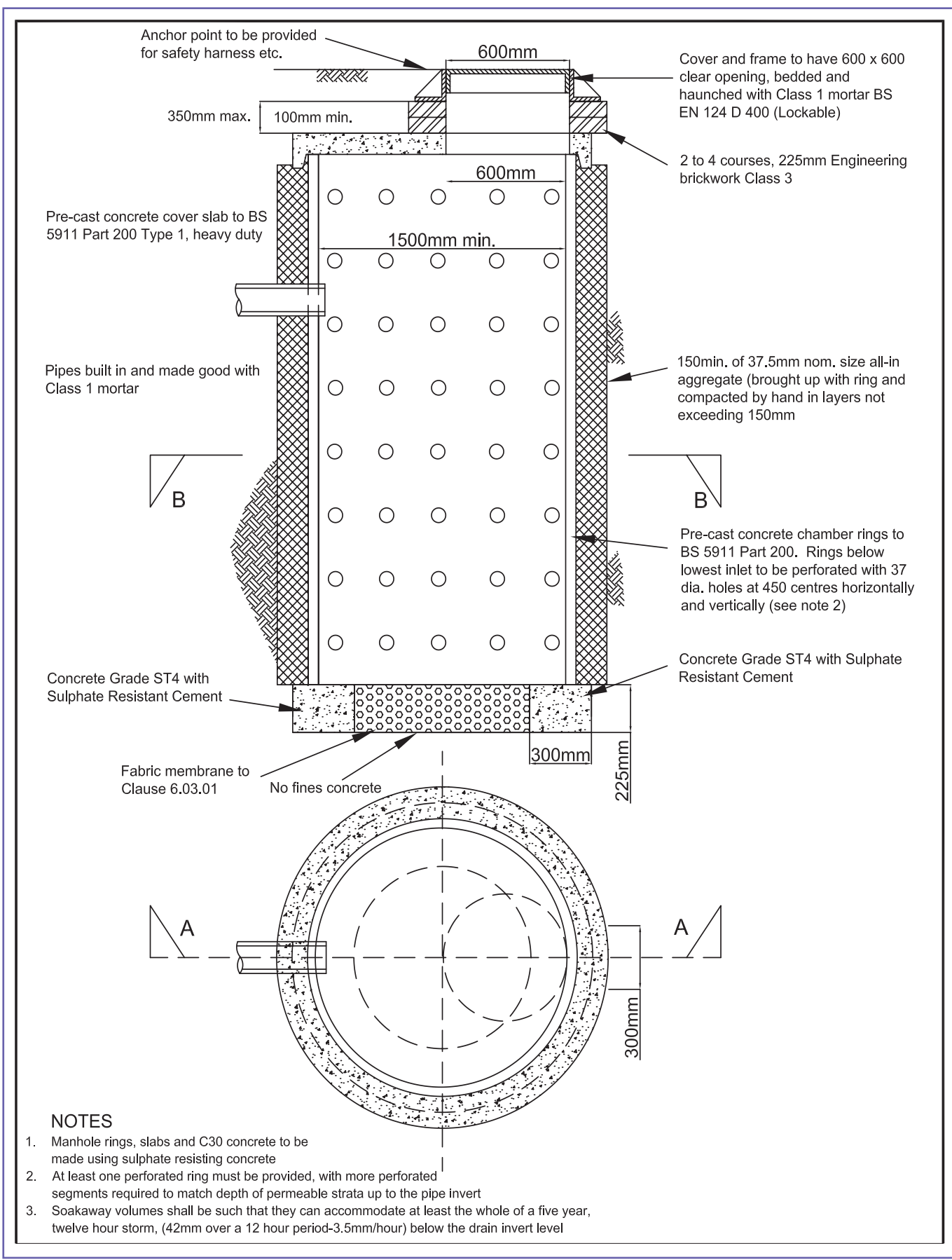

NOTES

1. Manhole rings, slabs and C30 concrete to be made using sulphate resisting concrete
2. At least one perforated ring must be provided, with more perforated segments required to match depth of permeable strata up to the pipe invert
3. Soakaway volumes shall be such that they can accommodate at least the whole of a five year, twelve hour storm, (42mm over a 12 hour period-3.5mm/hour) below the drain invert level

Drawing 014: Typical Outlet Headwall

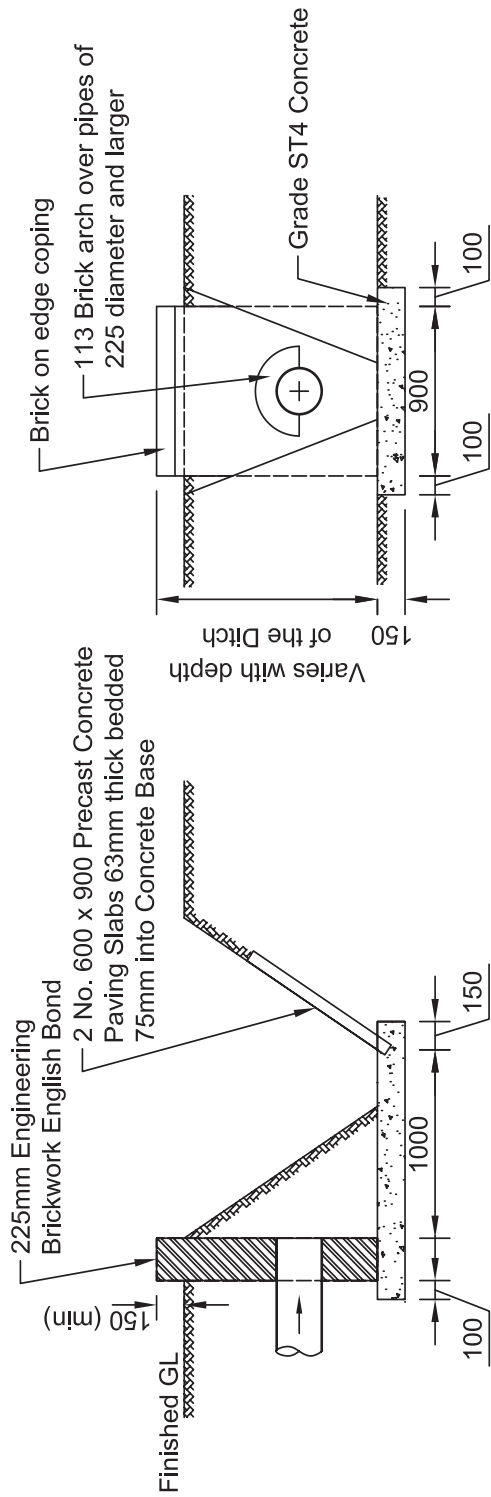

Section X - X

- Invert of pipe to be 300mm above channel base
- Overall concrete channel width to be 1.475m

Section A - A

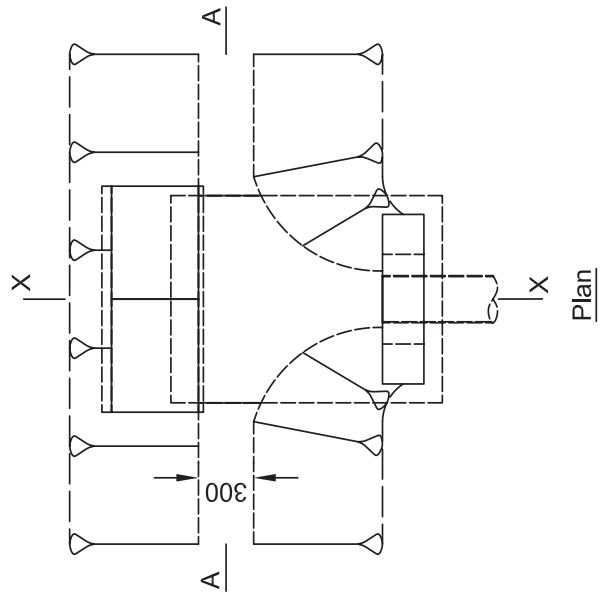

CONSTRUCTION SPECIFICATION

Drawing 015: Street Lighting Column Groups I and IA

MOUNTING HEIGHT H (m)	PLANTING DEPTH A (m)	BASE DIAMETER OD1 (m)	SHAFT DIAMETER OD2 (m)
5	0.80	0.140	0.076
6	1.00	0.140	0.076

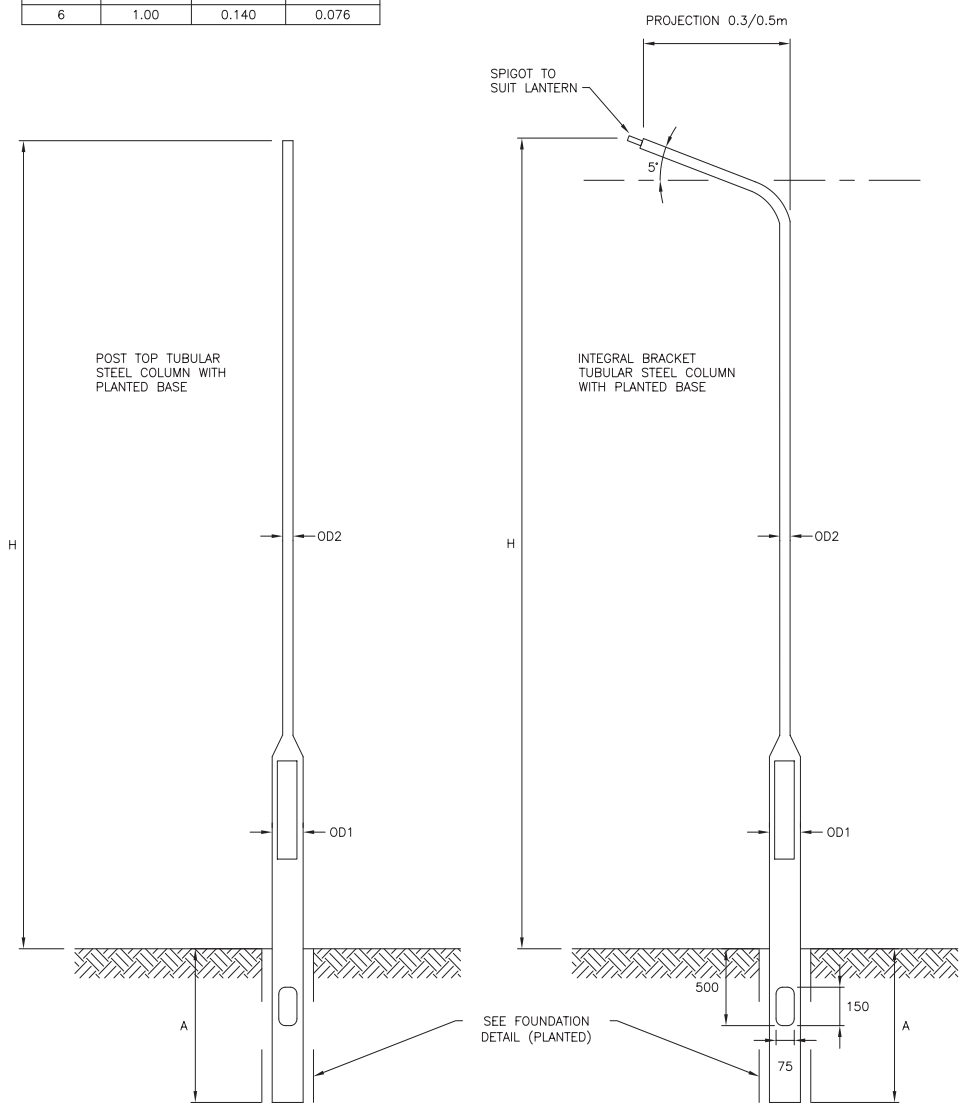

GROUP 1A

GROUP 1

- NOTES
1. ALL DIMENSIONS ARE IN MILLIMETRES UNLESS SHOWN OTHERWISE.
 2. ALL DIMENSIONS SHOWN ARE MINIMUM DIMENSIONS.
 3. ALL SCREWS TO BE STAINLESS STEEL (BRASS EARTH SCREW).
 4. COLUMN AND BRACKET TO BE OF ONE PIECE TUBULAR STEEL CONSTRUCTION.
 5. THE LANTERN MOUNTING SPIGOT IS TO BE PARALLEL WITH THE BRACKET.

Drawing 016: Street Lighting Column Groups 2 and 2A

MOUNTING HEIGHT H (m)	PLANTING DEPTH A (m)	BRACKET PROJECTION P (m)
8	1.20	1.00
10	1.50	1.50
12	1.70	2.00

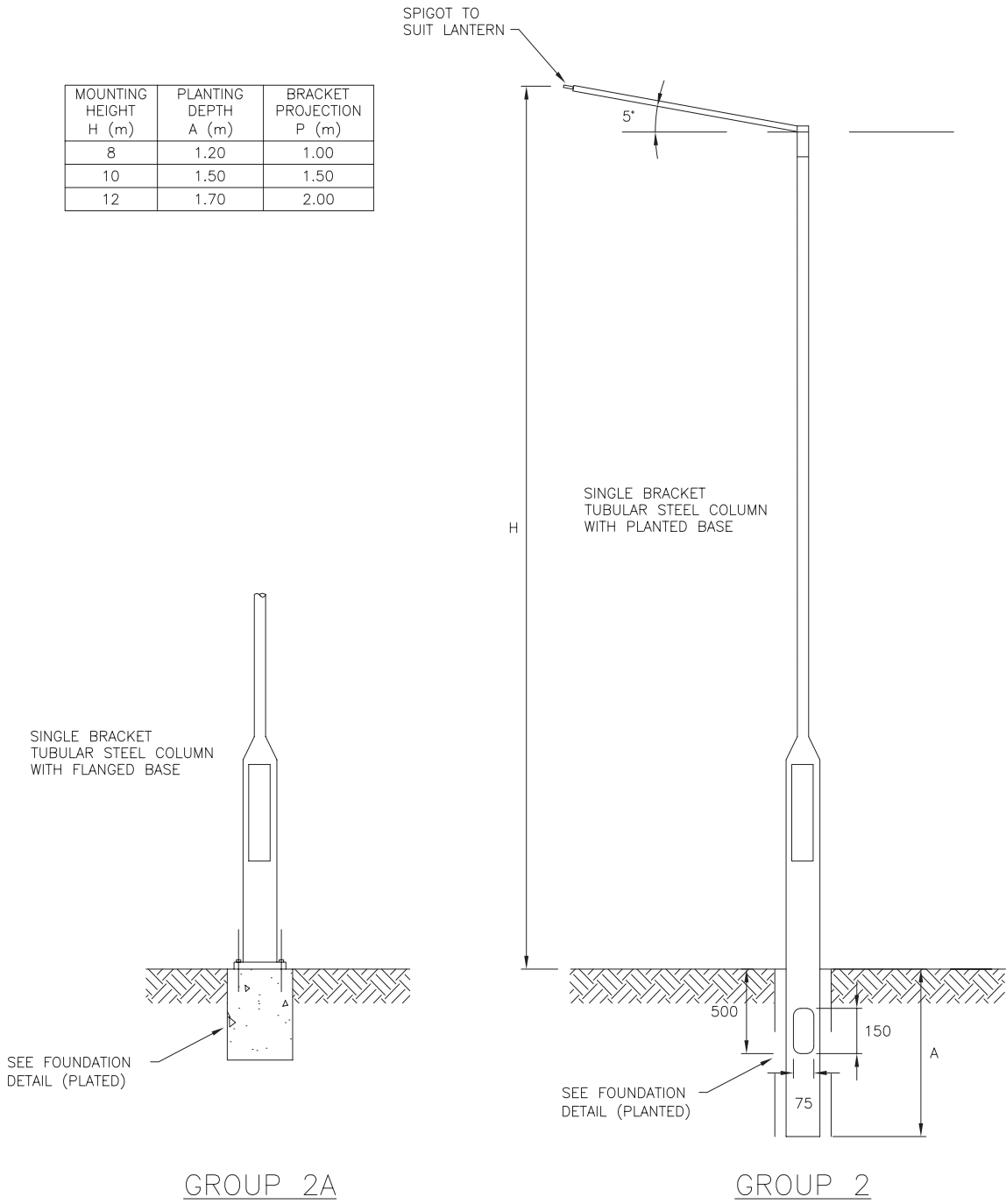

NOTES

1. ALL DIMENSIONS ARE IN MILLIMETRES UNLESS SHOWN OTHERWISE.
2. ALL DIMENSIONS SHOWN ARE MINIMUM DIMENSIONS.
3. ALL SCREWS TO BE STAINLESS STEEL (BRASS EARTH SCREW).
4. THE LANTERN MOUNTING SPIGOT IS TO BE PARALLEL WITH THE BRACKET.

CONSTRUCTION SPECIFICATION

Drawing 017: Street Lighting Column Foundation Details (Planted)

Planting Height H (m)	Planting Depth A (m)	Base Concrete Depth Y (m)
5	0.75	0.60
6	1.00	0.85
8	1.20	1.05
10	1.50	1.35
12	1.75	1.60

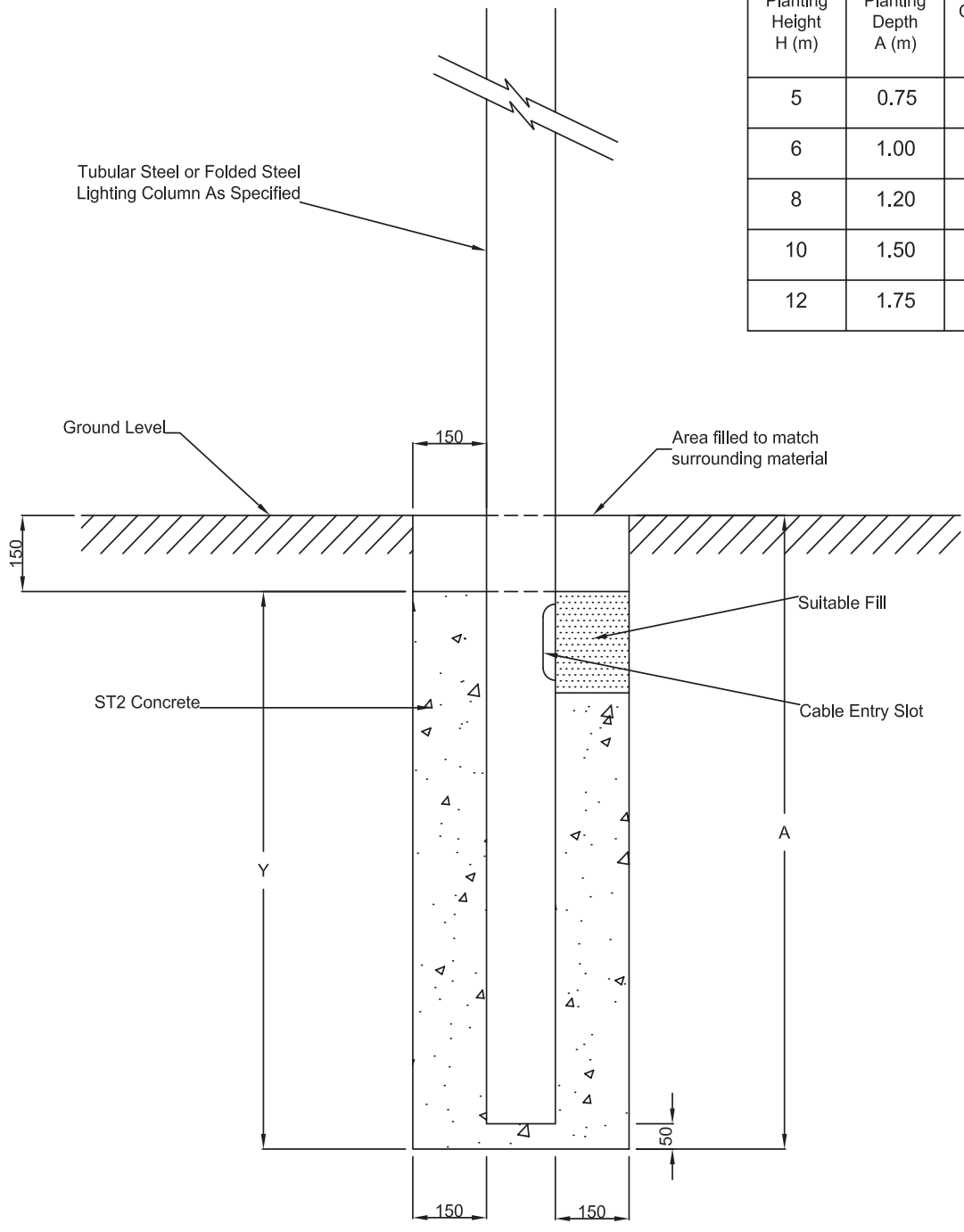

NOTES

1. All Dimensions in millimetres

Drawing 018: Highway Tree Section

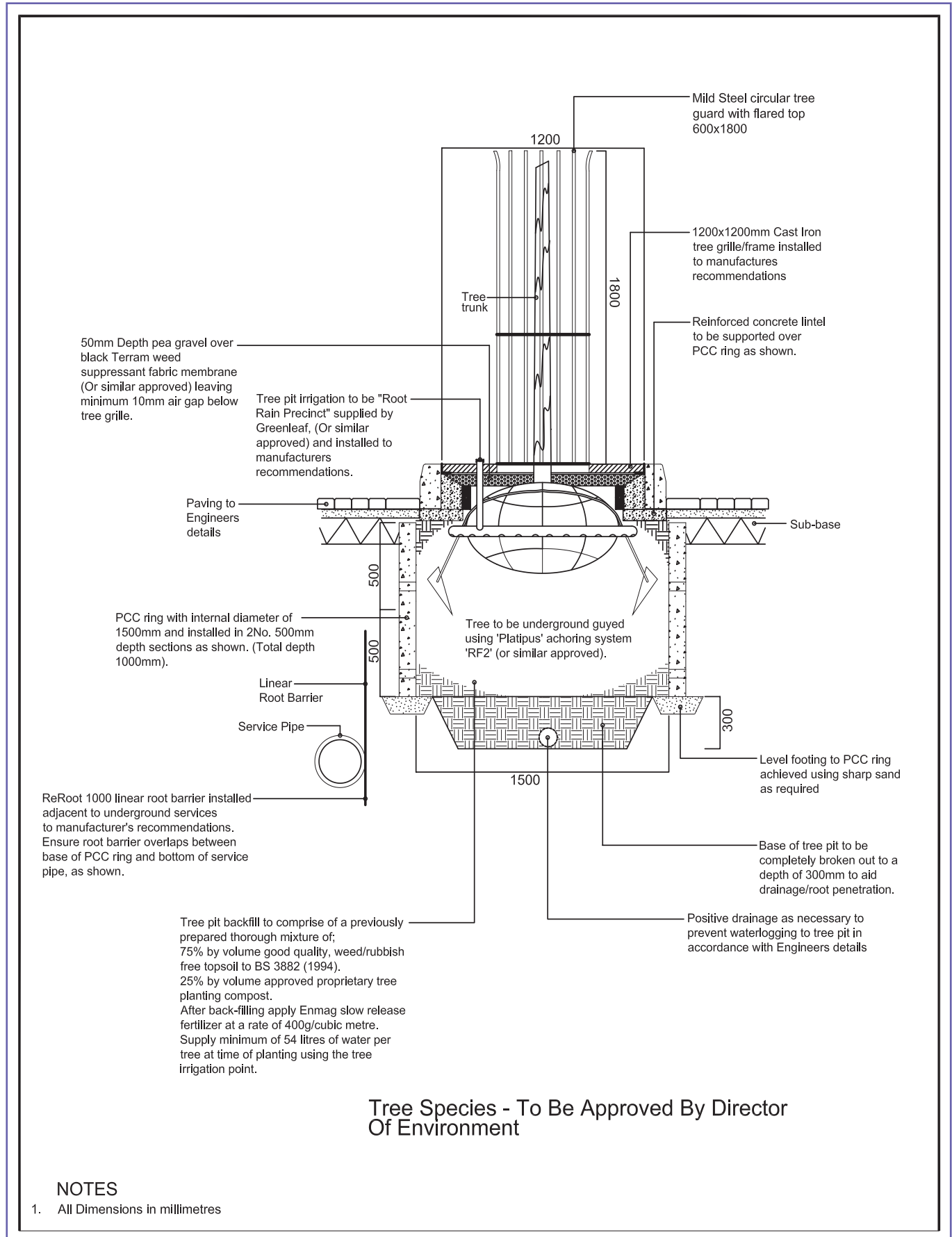

CONSTRUCTION SPECIFICATION

Drawing 019: Highway Tree Plan

